



Strategi[®]

User guide and technical specification

Strategi

User guide

Contents

Section	Page no
Preface	3
Contact details	3
Use of the product.....	3
Purpose and disclaimer	3
Copyright in this guide	3
Data copyright and other intellectual property rights	4
Trademarks	4
Back-up provision of the product	4
Using this guide.....	4
Chapter 1	5
Strategi – a summary.....	5
Strategi features.....	5
Strategi benefits	5
Strategi applications.....	6
Requirements to use Strategi	6
Computer hardware	6
Computer software.....	6
Strategi supply	6
Supply unit	6
Supply options	6
Transfer formats.....	7
Media	7
Data supply structure.....	7
CD naming conventions.....	7
Strategi version numbering (or specification)	8
NTF release	8
Strategi output options	8
Strategi application overview	9
Typical user scenarios	9
Chapter 2	10
High-level product overview	10
Source of Strategi	10
Currency.....	10
Accuracy and resolution.....	10
Completeness	10
Chapter 3	11
Strategi content.....	11
Feature theme description	11
Communications	11
Water features	14
Settlements	15
Boundaries.....	16
Land use	16
Other features	17
Miscellaneous	18
Text	18
Chapter 4	21
The National Grid	21
Annexe A	22
Product and service performance report form	22

v8.2 – 02/2011

D05300_05

Preface

This user guide (hereafter referred to as the guide) is designed to provide an overview of Strategi (hereafter referred to as the product) and it gives guidelines and advice on how a customer might derive the maximum benefit from the product. It assumes a general knowledge of geographic information. If you find an error or omission in this guide, or otherwise wish to make a comment or suggestion as to how we can improve it, please contact us at the address shown below or complete the product and service performance report form at [annexe A](#) and return it to us.

Contact details

Our Customer Service Centre will be pleased to deal with your enquiries:

Customer Service Centre
Ordnance Survey
Adanac Drive
SOUTHAMPTON
SO16 0AS

General enquiries (calls charged at local rate): +44 (0)8456 05 05 05

Dedicated Welsh Language HelpLine: 08456 05 05 04

Textphone (deaf and hard of hearing users only please): +44 (0)23 8005 6146

customerservices@ordnancesurvey.co.uk

www.ordnancesurvey.co.uk

This document has been screened in accordance with the requirements set out in Ordnance Survey's Equality scheme. If you have difficulty reading this information in its current format and would like to find out how to access it in a different format (Braille, large print, computer disk or in another language), please contact us on: +44 (0)8456 05 05 05.

Use of the product

The product is made available to you and your organisation on the terms of the OS OpenData Licence at www.ordnancesurvey.co.uk/opendata/licence.

If there is any inconsistency between the terms of the licence and this guide, the terms of the licence prevail.

Purpose and disclaimer

This guide is provided for guidance only and does not constitute any warranty, representation, undertaking, commitment or obligation (express or implied) about the product or its suitability for any particular purpose. Any warranties, representations, undertakings, commitments and obligations given by Ordnance Survey about the product and/or its suitability for any particular or intended purpose are set out in your customer contract. It is your responsibility to ensure that this product is suitable for your intended purpose.

Ordnance Survey does not accept any liability (whether for breach of contract, negligence or otherwise) for any loss or liability you or any third party may suffer in relying on this guide and any guidance, suggestion, advice or explanation provided in it. Ordnance Survey's liability to you in relation to the product is limited, as set out in the OS OpenData Licence.

We may change the information in this guide at any time without notice.

We do not accept responsibility for the content of any third party websites, referenced in, or accessed through, this guide or through the Ordnance Survey website.

Copyright in this guide

This guide is © Crown copyright 2011. All rights reserved.

You may copy or distribute any part of this guide to support the use of OS OpenData, including for your personal use, use in your organisation or business, or for use with, or incorporation in, your product or application.

Data copyright and other intellectual property rights

The Crown (or, where applicable, Ordnance Survey's suppliers) owns the intellectual property rights in the data contained in this product. You are free to use the product on the terms of the OS OpenData Licence, but must acknowledge the source of the data by including the following attribution statement: Contains Ordnance Survey data © Crown copyright and database right 2011.

Trademarks

Ordnance Survey, the OS Symbol, OS OpenData, OS MasterMap, Strategi and Travelmaster are registered trademarks of Ordnance Survey, the national mapping agency of Great Britain.

Adobe and Reader are registered trademarks of Adobe Systems Incorporated.

ArcView and ESRI are registered trademarks of Environmental Systems Research Institute, Inc.

Arial and Corsiva are registered trademarks and Times New Roman is a trademark of The Monotype Corporation.

AutoCAD and Autodesk are registered trademarks and DXF is a trademark of Autodesk Inc.

Excel is a registered trademark of Microsoft Corporation.

GEOPLAN is a registered trademark of Geoplan Spatial Intelligence Limited.

Helvetica is a registered trademark of Heidelberger Druckmaschinen AG.

MapInfo is a registered trademark of MapInfo Corporation.

Back-up provision of the product

You are advised to copy the supplied data to a back-up medium.

Using this guide

The documentation is supplied in portable document format (PDF) only. Free Adobe® Reader® software, which displays the guide, incorporates search and zoom facilities and allows you to navigate within. Hyperlinks are used to navigate between associated parts of the guide and to relevant Internet resources by clicking on the blue hyperlinks and the table of contents.

If you are unfamiliar with any words or terms used and require clarification please refer to the [glossary](#) at the end of the document.

Chapter 1 Strategi – a summary

Strategi is digital vector data and is a representation of Ordnance Survey's 1:250 000 scale graphic products. As such, it is ideal for applications requiring an overview of generalised geographic information of England, Scotland and Wales. It supports a wide range of applications, including planning or environmental analysis. Users can geographically link their business information with Strategi to analyse national trends or to provide a planning overview, for example, the provision of a framework for road scheme planning using this small scale national dataset.

The data has been digitised from Ordnance Survey's published mapping at 1:250 000 scale.

As Strategi is supplied as data only, appropriate software is needed to use the data for your intended application.

Strategi features

Strategi contains the following features:

- Road, railways, airports and ferries: for example motorways, primary routes, A and B roads, minor roads, footpaths, airports, heliports and vehicular ferries.
- National, national park and Administrative boundaries.
- Water features: rivers, canals, lakes and reservoirs, sea, coast.
- Woods and land use: woodland areas, windmills, Roman roads, battlefields.
- Cities, towns and other settlements: primary and non-primary route destinations and urban areas.
- Positioned geographic names: water features, motorway numbers.

Strategi benefits

The specification of Strategi offers a number of benefits:

- National coverage.
- The definitive 1:250 000 scale dataset for Great Britain suited to multiple applications using a geographical information system (GIS), computer-aided design (CAD) and digital mapping systems.
- A vector format, allowing the building of closed polygons. However, networks within the data are incomplete.
- Annually updated from a maintained data source.
- Gazetteer – as part of the Strategi package, a 1:250 000 scale names gazetteer is supplied. The text files will contain the settlement name, admin area, and National Grid coordinates. Text searches can be carried out on the ASCII file or it can be imported into a spreadsheet/database or can be taken into a GIS environment.

Strategi applications

Strategi provides a comprehensive national database of geographic (spatial) information designed to support a wide range of applications. Strategi is a small-scale cartographic base for strategic planning and analytical processes.

The list of potential applications includes:

- customised graphic output;
- environmental analysis;
- 'what if' analysis;
- statistical analysis for social, environmental or marketing decision making;
- linking and integrating user's own information with spatial data; and
- visual route planning.

Requirements to use Strategi

Computer hardware

This product may be used on a wide range of hardware platforms (provided sufficient memory and storage facilities are available). However, you may need extra memory capacity for DXF data.

Computer software

Strategi is supplied as data only and does not include software for data viewing or manipulation. Strategi supplied in NTF or DXF will require specific software such as GIS or CAD.

NTF is a nationally-agreed standard for the transfer of geographic data. NTF allows users of GIS to customise their own definition of the data for display and/or plotting for their specific applications.

Strategi is also available as data in Mid/Mif and Shapefile formats, which can be imported into almost all current versions of GIS software.

Strategi supply

Supply unit

Strategi is supplied as seamless data files. In NTF and DXF Great Britain is supplied as two files – GB north and GB south.

In Strategi Open Data, DXF is supplied as one GB file.

The gazetteer is supplied as an ASCII list with asterisk (*) separated columns, providing GB coverage.

Supply options

The options for data supply are as follows for both NTF, DXF, Mid/Mif and Shapefile formats:

- a complete database of Great Britain;
- country datasets:
 - England;
 - North;
 - South;
 - Mid;
 - Scotland; and
 - Wales.

Transfer formats

This user guide supports the following formats:

- BS 7567 (NTF v2.0 Level 3).
- DXF conforming to AutoCAD release 12 with extended entity data.

Media

Strategi is supplied on CD-ROM only.

Data supply structure

Root directory SHP:

```
|_DOCUMENTS
|   |_STRATEGI_AREA.TXT
|   |_STRATEGI_RELEASE_2010_CHANGE.TXT
|_GAZETTEER
|   |_DATA
|       _STRATEGI_20101_GAZETTEER.TXT
|_GB2
|   |_SHAPE
|       |_DATA
|           |_info
|           |_textadmin
|           |_textother
|           |_texttrans
|_STRATEGI_README.TXT
```

Root directory MI, NTF, DXF:

```
|_DOCUMENTS
|   |_STRATEGI_AREA.TXT
|   |_STRATEGI_RELEASE_2010_CHANGE.TXT
|_GAZETTEER
|   |_DATA
|       _STRATEGI_20101_GAZETTEER.TXT
|_GB2
|   |_MID_MIF3
|       |_DATA
|_STRATEGI_README.TXT
```

¹ This is the year of release

² This indicates the coverage, in this instance Great Britain.

³ This indicates the format of the data, in this example MID/MIF

CD naming conventions

The following convention will be adopted for labelling the CDs, (for example, *Strat04MIGBN* where *Strat* is the product identifier, *04* is the year of release, *MI* is the format and *GBN* is the region of coverage):

- Format; NTF, MI, SHP, or DXF (NTF, MID/MIF, SHAPE or DXF respectively).
- Region; GBN, GBS, EN, EM, ES, SC, or WAL (GB North, GB South, England North, England Midlands, England South, Scotland or Wales respectively).

Strategi version numbering (or specification)

The following gives details of the product specification identity and their relationship to Ordnance Survey data capture specifications. This user guide reflects the product specification current at the date of this user guide. Version details of these specifications are also stated.

Product Product specification

Strategi Strategi_02.00

Transfer format specifications:

Name	BS 7567 (NTF v2.0)	DXF (release 12)
Level	3	
Version	2	1
Issue date	15 May 1992	1 January 1997

NTF release

The current release is NTF v2.0. The NTF version is indicated by the {NTFVER} field of the volume header record [VOLHDREC]. The effective date of the definition of NTF v2.0 in Strategi is 15 May 1992 and is indicated by the {DDATE} field of the database header record.

Strategi output options

Strategi is inert data. It requires software (not provided by Ordnance Survey) to display it on a screen or to plot it out as hard copy.



The parameters defining colours, line styles, text styles, symbols and so on should be built into user software.

Strategi may be customised by viewing or plotting features in different colours, line styles and scales to suit different applications. Certain classes of features may be omitted from customised plans on the basis of selection by feature code and attributes.



The parameters defining colours, line styles, text styles, symbols and so on are embedded within the DXF file, as is customary with this CAD format.

The resolution of Strategi will support plotted or displayed output at a range of scales around the nominal scale of the source mapping.

NOTE: plotting at too small a scale will result in a map of cluttered appearance, with text too small to be legible.

A suggested output within 25% of a map's source scale of 1:250 000 should allow all data to be sensibly plotted or displayed. This translates as 1:187 500 minimum or 1:312 500 maximum scales.

Strategi application overview

Typical user scenarios

Strategi is a national database of Great Britain and can form the geographic information base for use with a GIS. Here are two examples:

Example 1: site research for a large-scale multiple retail outlet

Increasingly, retail businesses are looking for competitive advantage; therefore, investment in retail outlets requires careful, efficient, objective and quantified approaches to planning. Where are the ideal locations to site these? What is the local infrastructure like? What is the demographic profile of the local population?

Scenario: a retailer is looking for a site in Hampshire. The company's criteria for selection are as follows:

- the site must be within a 3 km buffer of an inferred motorway junction;
- the site must be within a catchment area of a large urban area; and
- the nearest competitor should not be within 5 km – information derived from the retailer's own competitor database.

Additionally, the researcher needs to know which postcodes are contained within this urban area to enable the company to link to their own demographic database.

Example 2: environmental analysis

Scenario: within the county of Hampshire, an environmental authority needs to know which woodland parcels (land areas) of 500 hectares or more are contained wholly within the county, to assist them in their woodland management programme.

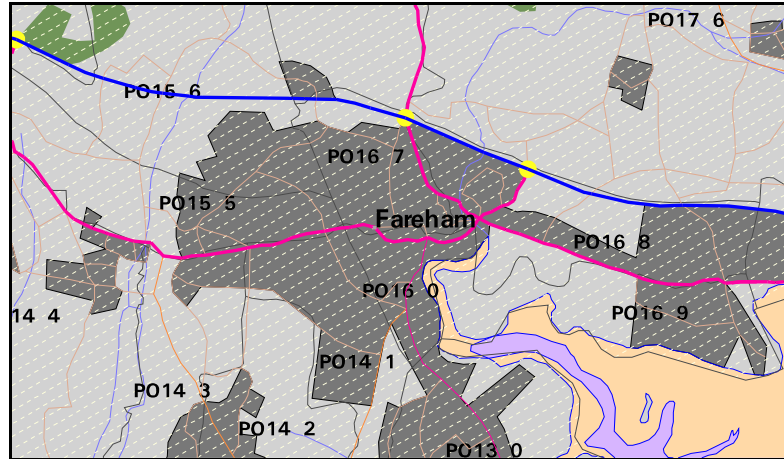

Figure 1.1: site research

GEOPLAN® postcode data supplied courtesy of Geoplan.
*NOTE: postcode data is **not** supplied with Strategi.*

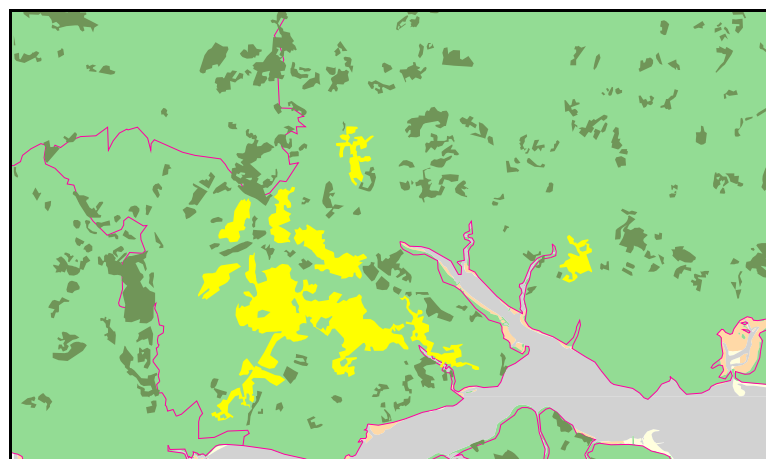

Figure 1.2: woodland parcels – light areas indicate woodlands of 500 hectares or more.

Chapter 2 High-level product overview

Source of Strategi

Strategi data is a direct export from Ordnance Survey's 1:250 000 scale database.

The Strategi gazetteer is created from the settlement names held in the 1:250 000 scale database.

Currency

Strategi updates are released annually. Each update is a replacement dataset for all Strategi data held. The updates represent Strategi features as at a date that falls, typically, during the preceding July, with major roads information advanced to the end of that year.

Accuracy and resolution

Strategi is produced from data that is used to create Ordnance Survey's 1:250 000 scale graphic mapping. Such mapping is subject to map generalisation – information is cartographically represented in areas where accurate positional representation would cause confusing clutter on the map. Features are selected and positioned according to a predefined specification criterion, adjusting or omitting detail where appropriate.

The resolution of the coordinate system is 1 m. However, it is not possible to calculate meaningful accuracy limits for this data, due to both the graphic nature and scale of the source 1:250 000 scale mapping.

Nevertheless, the original data was digitised to an accuracy of 0.1 mm, at scale, of the line centre of the original document. The shape of any feature is not altered within this tolerance. When the original centreline is regenerated from the original data by joining coordinates with straight lines, no point on the line should deviate from the original centre by more than 0.2 mm.

Completeness

Completeness is a measure of the correspondence between the real world and the specified data content.

Chapter 3 Strategi content

Feature theme description

On the following pages, the feature codes are grouped into themes for easy reference, with explanatory notes where appropriate.

Strategi feature codes are numerically listed in detail within the technical specification section in [chapter 1 for NTF](#) and [chapter 4 for DXF](#).

NOTE: names, where recorded as attributes, appear in all themes.



Feature codes are prefixed with G806 for DXF.

Communications

Feature description	Feature code
Motorways	
normal	5310
over other feature	5312
under construction	5300
under construction, over	5301
planned	5311
Motorway tunnel	5313
Motorway junction	
full access	5370
limited access	5371
under construction	5372
Primary routes	
Dual carriageway	5320
over other feature	5322
under construction	5302
under construction, over	5303
planned	5321
roundabout	5355
Single carriageway	5323
over other feature	5325
under construction	5304
under construction, over	5305
planned	5324
roundabout	5375
Narrow	5326
over other feature	5327
Tunnel	5373

Feature description	Feature code
Dual carriageway	5330
over other feature	5332
under construction	5306
under construction, over	5307
planned	5331
roundabout	5356
Single carriageway	5333
over other feature	5335
under construction	5308
under construction, over	5309
planned	5334
roundabout	5376
Narrow	5336
over other feature	5337
tunnel	5358
B roads	
Dual carriageway	5340
over other feature	5342
roundabout	5357
Single carriageway	5343
over other feature	5345
roundabout	5377
Narrow	5346
over other feature	5347
Tunnel	5359
Minor roads – over 4 m wide	
Normal	5350
over other feature	5351
roundabout	5374
tunnel	5353
Minor roads – under 4 m wide	
Normal	5405
over other feature	5406
roundabout	5408
tunnel	5407
Dead end roads	5403
Dead end roads, over	5404
Other track or road	5384
Other track or road, over	5385

Feature description	Feature code
Additional road features	
Multilevel junction (primary A, B and minor roads)	5379
full access	5379
limited access	5389
under construction	5378
Roundabout – under construction (all roads)	5381
Gradient – 1 in 7 (14%) or steeper (primary A and B roads only)	5380
Road tunnel end symbol (all tunnels)	5314
Toll bar (all roads)	5382
Services (motorway, primary routes and A roads)	
full access	5360
limited access	5361
Services station (non-24 hour – primary and A roads only)	5392
Railways	
Standard gauge	5510
over other feature	5511
Narrow gauge	5512
over other feature	5513
Railway tunnel	5514
Railway line under construction	5519
Railway station	5520
Rapid transit station	5521
Rapid transit line	5522
Rapid transit line, over	5523
Rapid transit tunnel	5524
Rapid transit line (U/C)	5525
Level crossing	
classified roads	5530
unclassified roads	5531
Airport	
with customs, no scheduled flights	5839
without customs facilities	5840
with permanent customs facilities	5841
Heliport	5845
Ferries	
vehicular ferry route	5390
ferry route link	5393
National trails, long distance path and route	5825

NOTE:

- A selection of roads classified by the Department for Transport (DfT) are represented in the data and identified as dual carriageway, single carriageway or narrow roads with passing places. Please note, however, that for clarity of representation some classified roads will have been omitted.
- Vehicular ferries are included within the data.
- Railway information includes all standard-gauge railways and a selection of their associated infrastructure such as stations and tunnels. However, again, please note that, for clarity, a selection of railway stations have been omitted.
- Narrow-gauge railways are included where space permits.

Water features

Feature description	Feature code
Coastline	
natural, man-made and offshore rocks above mean high water (MHW)	5110
Sea area seed (below MHW)	5115
Foreshore area	
sand, outer limit	5120
sand, inner limit	5494
sand seed	5121
other, outer limit	5122
other, inner limit	5495
other seed	5123
River (primary)	
source	5211
middle	5212
lower	5213
River (secondary)	
source	5221
middle	5222
Other river and drains	5230
Canal	
normal	5240
over other feature	5242
tunnel	5241
Inland water (lake, reservoir, loch, pond, shoreline and so on)	
outer limits	5250
inner limit	5490
area seed	5251
Lighthouse	
in use	5140
disused	5142
Lightship	5141

NOTE:

- Rivers and canals do not pass through lakes and reservoirs.
- A dam or barrage is not distinguished from the shore.
- Foreshore detail is identified as sand or other, which makes sand areas easily identifiable.
- Information on lighthouses and lightships is also included and is represented by a point feature.
- Sea areas are identified with an unbounded sea seed point; its precise position is not important. Examples of sea seed points include those that denote the Bristol Channel and Falmouth Bay.

Settlements

Developed land use area

Definition: an area containing a concentration of buildings and other structures. An isolated building within a remote area would also constitute a developed land use area.

Capture: these areas must have a road of any classification connecting it to the road network. If this road is not present, it will not be captured.

An urban area greater than 1 square km is captured as a large urban area, and an urban area less than 1 square km is captured as a small urban area.

An open area within an urban area less than 0.5 square km is not captured.

Feature descriptions and codes are defined below:

Feature description	Feature code
Settlement attribute points	
city	5427
town	5413
village	5416
landmark feature (retail/industrial estates and so on)	5419
Urban area	
large, outer limit	5420
large, inner limit	5492
large, seed	5421
small, outer limit	5422
small, inner limit	5493
small, seed	5423

NOTE:

- Settlements show outer limits and open spaces within urban area outer limits.
- Primary and non-primary route destinations are held as an attribute of the settlement feature codes.

Boundaries

Feature description	Feature code
National boundary	5710
National primary attribute point	5715
County boundary	5720
County primary attribute point	5725
Unitary authority boundary	5740
Unitary authority primary attribute point	5744
District boundary	5730
District primary attribute point	5733
Associated area boundary (arbitrary boundary, for example, between islands)	5750
Administrative area detached attribute point	5734
National, forest park boundary	5820
National, forest park attribute point	5821

NOTE:

- *The data associated with administrative area seed points contains the name of the administrative area. This is the means by which separated areas of the same administrative area unit are linked together.*
- *Seed points have associated boundary codes. In the case of national seed points, these are coastline and the national boundary. In the case of county seed points these are coastline, national and county boundaries. In the case of district seed points there are coastline, national, county and unitary boundaries. Any number of separated areas of the same administrative area unit may carry the seed point code.*
- *Offshore islands will carry administrative area seed points but not the national seed point. Small islands and rocks, coded as point features, do not have area seed points. There is no logical connection in the data between them and Administrative Units.*

Land use

Feature description	Feature code
Wood, forest	
outer margin	5610
inner limit	5491
seed	5611
Marsh	5612
Island area attribute point	5621
Geographic area attribute point (parks, moors, woodland, headland, fens, commons, plains, large hills and summits, small hills and other physical features)	5620

NOTE: woodland margins and clearings are included in the land use category along with woodland area seeds.

Other features

Feature description	Feature code
Antiquities	
Roman road	5810
antiquity line detail (dyke, wall and so on)	5812
hill fort	5815
battlefield	5816
Landmark/antiquity dot (hotel, ruin, castle and so on)	5838
Telephone dot	5837
Television or radio mast	5835
Wind-powered generator	5843
Windmill	5844
Tourist	
abbey, cathedral, priory (open to the public)	5860
aquarium (open to the public)	5875
camping and caravanning combined site	5805
campsite	5861
caravan site	5862
castle (open to the public)	5877
cave (open to the public)	5876
country park (open to the public)	5867
craft centre (open to the public)	5873
ferry box outline	5890
ferry boat	5887
ferry catamaran	5892
ferry hovercraft	5888
garden (open to the public)	5886
golf course	5863
historic house (open to the public)	5878
motor racing circuit	5879
museum (open to the public)	5864
nature or forest trail	5869
nature reserve	5880
other tourist attraction (open to the public)	5883
park and ride	5806
picnic site	5865
preserved railway	5871
racecourse	5885
ski slope	5884
telephone (motoring organisation)	5849

Feature description	Feature code
telephone (public)	5847
theme park (open to the public)	5851
tourist information centre (open all year)	5866
tourist information centre (seasonal)	5889
viewpoint (360°)	5882
viewpoint (limited)	5881
wildlife centre (open to the public)	5874
youth hostel	5868
zoo (open to the public)	5870
Height	
spot-height dots	5901

Miscellaneous

Feature description	Feature code
100 km accentuated grid line	5397
10 km grid line	5398
Dual junction driver line	5109
Road distance marker – motorway	5108
Road distance marker – primary and A road	5107

Text

NOTE: font styles apply only to NTF; text for DXF is STANDARD.

Feature description	Feature code	Font
Primary route destination		
city	5025	0008
town	5041	0008
village	5049	0008
Non-primary route destination		
city	5026	0008
town	5006	0008
village	5040	0003
Road numbers		
motorway	5031	0001
primary route	5032	0001
A road	5033	0001
B road	5034	0005

Feature description	Feature code	Font
Dual junction divider line	5109	–
Motorway junction numbers		
full access	5042	0003
limited access	5043	0003
Services text	5048	0003
Toll	5038	0002
Road distance mileage		
motorway	5036	0002
primary and A road	5037	0002
Road distance marker		
motorway	5108	–
primary and A road	5107	–
Geographic area names (parks, moors, woodlands, commons, moors, plains)	5060	0006
Large hills, ranges and summits	5061	0007
Named hills, islands and rocks	5062	0006
Other text (airports without customs facilities, heliports, hotels, oil refineries and so on)	5016	0003
Water features (rivers, lakes, lochs, reservoirs, bays, seas, oceans and so on)	5020	0006
Tourist feature	5044	0004
Ferry annotation	5039	0001
National trails, long distance path and route	5045	0002
National park, forest park	5046	0002
Spot-height values	5090	0004
Antiquities		
Roman (AD 43–AD 420)	5081	0004
Non-Roman	5082	0009
County name	5721	0001
Unitary authority name	5741	0001
District name	5731	0001

Includes all cartographically-positioned names used for graphic output. Names have been transferred in their stored map positions. A font differentiator is transferred, which enables the user to define the appearance of the text.

Ordnance Survey convention for the digitising of names is as follows: all names are digitised as point features, given as X and Y National Grid coordinates. The point has been digitised relative to the map feature it describes, and the actual point will represent one of the standard positions as illustrated in figure 2.1.

A full list of feature codes in Mid/Mif and their locations within the data folders can be found [here](#).

A list of all data labels and layer descriptions can be found at [annexe A](#).

Figure 2.1: standard Ordnance Survey text positions

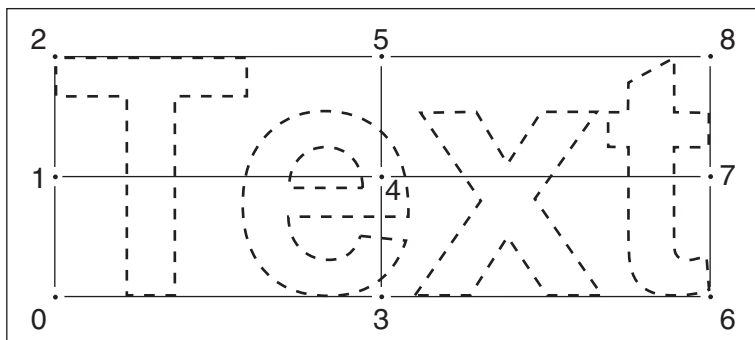

Names are normally placed on the printed map parallel to the horizontal grid. However, names of linear features, for example rivers, are orientated to appear parallel to them.

<p>BS 7567 NTF</p>	<p>The text string may start, end or be centred on this coordinate pair; the relationship of the text to its coordinate pair is expressed as an <i>original digitised position</i>. When the positions of text features are recorded, one of these positions is digitised.</p>
<p>DXF</p>	<p>Position 0 is supplied.</p>

The Strategi gazetteer in Excel[®] spreadsheet format can be imported into a GIS system such as MapInfo, where the eastings and northings can be converted to points enabling the data to be geocoded in order to map against the Strategi data layer.

Chapter 4 The National Grid

Strategi features are identified by a National Grid reference relative to the National Grid origin.

The National Grid divides Great Britain into squares 100 km by 100 km. Each of the squares has a unique two-letter reference, for example, HY in the diagram alongside.

To convert the absolute coordinates given in Strategi data to a 100 m grid reference, use the first number of the x and y coordinates to determine the reference letter (in the example below 03 and 10 equate to HY) and add this to the combined second, third and fourth coordinate numbers. For example:

absolute x coordinate: 03234444

and

absolute y coordinate: 10678888

equate to **HY234678**.

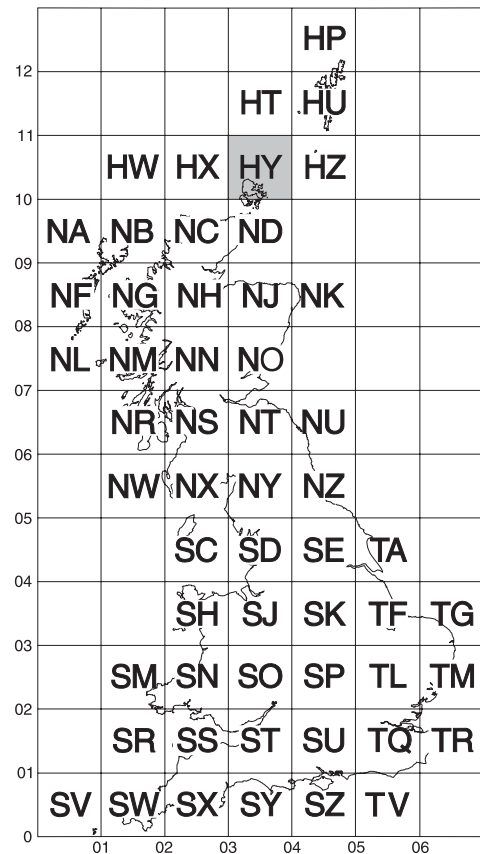

A Product and service performance report form

Ordnance Survey welcomes feedback from its customers about Strategi.

If you would like to share your thoughts with us, please print a copy of this form and when completed post or fax it to the address below.

Your name:

Organisation:

Address:

.....

.....

Postcode:

Phone:

Fax:

Email:

Quotation or order reference:

Please record your comments or feedback in the space below. We will acknowledge receipt of your form within three (3) working days and provide you with a full reply or a status report within 21 working days.

If you are posting this form, please send it to:

Strategi Product Manager, Ordnance Survey, Adanac Drive, SOUTHAMPTON, SO16 0AS.

If you wish to return it by fax, please dial +44 (0)8450 990 494.

Any personal information that you supply with this report form will be used by Ordnance Survey only in the improvement of its products and services. It will not be made available to third parties.

Strategi

Technical specification

Contents

Section	Page no
Introduction	25
Purpose of this specification and disclaimer	25
Copyright in this specification	25
Background information on the technical specification	25
Chapter 1	NTF explained 26
An overview of NTF	26
Chapter 2	Strategi NTF data structure 27
Data overview	27
Basic principles	27
Data structure	27
Features	28
Lines and points	28
Feature position	29
Feature attribute data	30
Information relevant to NTF	30
Coordinates	30
Bearings	30
Attribute codes	30
Transfer set structure	30
General	31
Section body	31
Point and line features	31
Name detail	32
Node detail	32
Data supply structure	33
Feature codes	34
Names as attributes	34
Over codes	34
Attribute codes for Strategi	35
Attribute values for Strategi	36
NTF feature codes for Strategi	36
Conventions used in this technical specification	43
Version management	43
Product version	43
Product release	44
NTF version	44
Chapter 3	Record structures for the transfer of Strategi in NTF 45
NTF record list	45
Volume header record [VOLHDREC] 01	46
Database header record [DBHREC] 02	47
Feature classification record [FEATCLASS] 05	48
Section header record [SECHREC] 07	49
Attribute record [ATTREC] 14	50
Point record [POINTREC] 15	53
Node record [NODEREC] 16	53
Two-dimensional geometry record [GEOMETRY1] 21	54
Line record [LINEREC] 23	56
Attribute description record [ATTDESC] 40	56
Text record [TEXTREC] 43	57
Text position record [TEXTPOS] 44	58
Text representation record [TEXTREP] 45	58
Volume terminator record [VOLTERM] 99	59
Chapter 4	DXF explained 60
Introduction	60

	An overview of Strategi in DXF	60
	Data Exchange Format (DXF)	60
	Structure of Strategi in DXF	60
	Feature representation.....	60
	Line features	60
	Area features	61
	Name features	61
	Information specific to DXF.....	61
	Coordinate system.....	61
	Height.....	61
	Layer names	61
	Neatline.....	61
	Grid	61
	Copyright.....	61
	Strategi DXF layers.....	62
Chapter 5	DXF file structure for Strategi.....	67
	General	67
	Data structure.....	67
	Header	68
	Tables	68
	Blocks	72
	Entities section.....	73
Chapter 6	An overview of Strategi in Mid/Mif	77
	Strategi is available in Mid/Mif	77
	Structure of Strategi in MapInfo	77
	Line features	77
	Area features	77
	Names features.....	77
	Drawing content and format.....	78
	Coordinate system.....	78
	Layer names	78
	Neatline.....	78
	Grid	78
	Grid values.....	78
	Mid/Mif layers.....	78
	1 Communications.....	79
	2 Water features	83
	3 Settlements.....	85
	4 Boundaries	85
	5 Land use.....	86
	6 Other features.....	86
	7 Miscellaneous.....	88
	8 Geographic text	88
	MIF file header information	92
	Attribution	92
Chapter 7	An overview of Strategi in ESRI Shapefile	93
	Shapefile attribution	93
Annexe A	Data labels and layer descriptions.....	94
Annexe B	Glossary.....	95

Introduction

Purpose of this specification and disclaimer

This is the technical specification (hereafter referred to as the specification) applicable to Strategi (hereafter referred to as the product).

We may change the information in this specification at any time.

We do not accept responsibility for the content of any third party websites referenced in or accessed through this guide or through the Ordnance Survey website.

Copyright in this specification

This guide is © Crown copyright 2011. All rights reserved.

You may copy or distribute any part of this specification to support the use of OS OpenData, including for your personal use, use in your organisation or business, or for use with, or incorporation in, your product or application.

Background information on the technical specification

Chapters 1 to 7 of the technical specification contain full information on Strategi data transfer formats.

The purpose of chapters 1 to 7 is to:

- Provide a brief description of the presentation of Strategi in the transfer formats in which it is supplied:
 - BS 7567 (NTF v2.0 Level 3); and
 - Mid/Mif.
- Also the two proprietary formats:
 - Data Exchange Format (DXF) (conforming to AutoCAD release 12 with extended entity data); and
 - Shapefile.

(As part of this brief description, data structure diagrams are used to give greater explanation where necessary).

- Provide Licensed Partners with as much detail as necessary to enable Strategi files in NTF, DXF, Mid/Mif or Shapefile to be easily understood and processed by application software.

The term *data structure* used in these chapters refers to the organisation and sequence of the records in the data file and not to the geographic topology of the data.

Because of the fundamental differences in the data format of Strategi supplied in NTF, DXF, Mid/Mif and Shapefile, this technical specification devotes separate chapters to these transfer formats.

Chapters 1 to 7 of the technical specification section should be read in conjunction with chapters 1 to 3 of the user guide, which describe the content of Strategi.

Chapters 6 and 7 of the technical specification section give details of Mid/Mif and Shapefile formats.

Please refer to the [glossary](#) if you are unfamiliar with any of the words or terms used.

Gazetteer – as part of the Strategi package a 1:250 000 scale names gazetteer is supplied on the CD (see [Data supply structure](#) in the user guide). The text files contain settlement name, admin area and National Grid coordinates.

- Data source: 1:250 000 scale topographic data.
- Data structure: ASCII list – table format, four columns:
 - settlements;
 - admin area;
 - eastings and northings; and
 - six-figure reference.
- Transfer formats text file.
- 48 000 names approximately.
- 1.960 Mb storage volumes.

Chapter 1 NTF explained

NOTE: for convenience, BS 7567 (NTF v2.0 Level 3) is referred to as NTF.

An overview of NTF

Strategi data is supplied in the British Standard National Transfer Format (NTF), and is transferred in Level 3 as variable length records.

The British Standard for NTF stipulates the following for Level 3:

'This level supports a variety of data models that may include network data, polygons, semantic relationships and complex features – for example, a school consisting of its buildings, boundaries and playing fields.'

This level is designed for:

- Transferring basic geometry and simple features through the use of geometry and feature records.
- Relating basic geometrical and topological elements to one or more features through the use of chain, polygon and complex line records.
- Combining features to form complex features through the use of collection and complex polygon records.
- Using text records to relate text strings to features and cartographic output.
- Referencing and positioning external features, for example, raster data.

The record structure at this level may also be defined to be compatible with data in Levels 1 and 2.

The governing body for the industry standard NTF is the British Standards Institution (BSI).

Their address is:

389 Chiswick High Road
LONDON
W4 4AL

Phone: 020 8996 9001
Fax: 020 8996 7001
Email: cservices@bsigroup.com

Any queries relating to the Strategi product should be referred to our Customer Service Centre at the [address shown](#) in the user guide.

The following pages give a detailed breakdown of the data structure of Strategi in NTF. This is a two-stage procedure that consists of:

- detailed listings of feature codes, descriptions and attributes; and
- descriptions of the data record structure.

Chapter 2 Strategi NTF data structure

Data overview

Basic principles

- Lines and/or links represent all linear features, for example, roads, railways, rivers, lakes and so on.
- Points represent individual map entities and may be either free-standing or enclosed by line features.
- Each feature has associated geometry; this may be a single coordinate pair for a single point feature representing a railway station, for example, or two or more coordinate pairs for a linear feature.
- Each feature is classified by means of a feature code that may have one or more associated attributes.
- Seed points are representative points that have attributes describing an area feature. They may fall within a polygon or be free-standing.

Data structure

Geographic features within Strategi are represented as: **points** – these are fixed positionally by one coordinate pair, for example, a roundabout feature; or **lines** – a series of connected coordinated points to represent digitally linear map features such as roads, rivers, settlement boundaries and so on. Points and lines within the data model determine the **geometric** (positional) characteristics of the data.

Lines and points within the data model also have associated **attributes** – these give the point or line entities meaning, that is they represent the descriptive characteristic of an entity such as a feature code, a name or a numerical value.



All features having the same feature code will be recorded on the same layer. DXF has a limited link and node structure; within this structure a feature may be a name, point or line. Each feature is free-standing (its topological relationship to any other feature is not expressed in the data).

Other important data structural concepts include:

Networks are intersecting linear features, or lines. In Strategi, networks do not have topological integrity; the implied junctions between lines may not be geometrically closed within the data. Proprietary GIS software can be used to build and maintain networks for linear features such as roads, railways and so on. However, not all data with the potential to be a network is structured into one.

Polygons are continuous areas defined by sets of bounding closed lines. These are implicit within the data, but can be explicitly created with appropriate software. Stored within recognisable polygons are **seed points**, sometimes described as centroids, which hold information about that polygon, for example, a town name. Unnamed polygons have a seed point that exists simply to represent the polygon feature, for example, an unnamed woodland area.

Figure 2.1: polygon

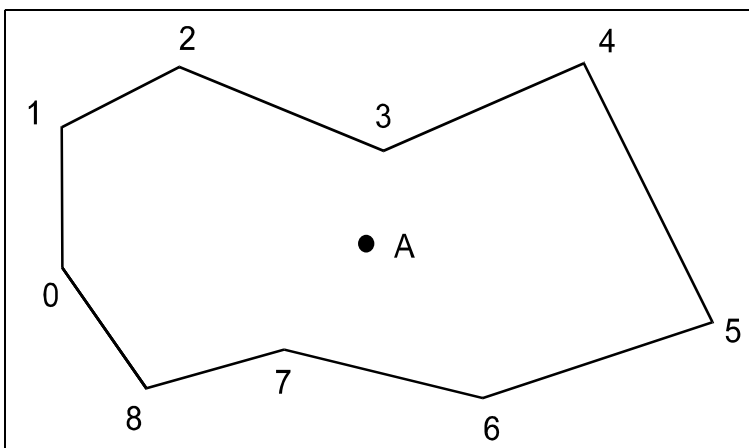

Point A is the polygon seed point for the area; attached to this point will be attributes, such as the feature code, which define it, and its definitive name – if it is named on the map. The polygon in this example comprises nine individual line segments.

There are also free-standing seed points that are not associated with a defining polygon. An example of such free-standing seed points is a geographical seed such as the South Downs.

GIS software provides the functionality to store, manage and manipulate this digital map data. The properties of Strategi make it suitable as the basis for users wishing to develop such applications.

Features

Strategi has two feature classes:

- point features; and
- line features.

These are arranged into recognisable map entities such as: roads, rivers, railways and lakes for line features; roundabouts, windmills, motorway junctions, and airports for point features. A full listing of individual features is given in [chapter 2](#) and in [chapter 5](#) for NTF and DXF respectively.

Each feature has two components:

- feature position; and
- attribute data.



Each feature recorded in Strategi should be considered as a DXF entity. Line features are recorded as DXF line(s) or polyline(s).

Point features will be recorded in the data as INSERT BLOCKS. Certain standard symbols are defined in the BLOCKS section of the data file. Attributes are stored as extended entity data.

Lines and points

Real-world geographic features are represented in the digital map data as geometric structures of lines and points. Each line or point has a geometric and attribute component.

The geometric component defines the positional characteristic of the feature, and implicit relationships exist between the lines and points based on relative position. The attribute component defines the descriptive characteristics of the feature.

Points may exist independently of lines.

An example of a geometric structure is shown in figure 2.2a.

Figure 2.2a: a geometric structure of lines and points.

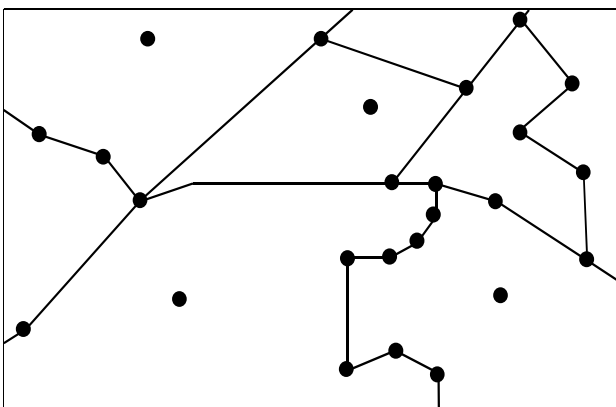
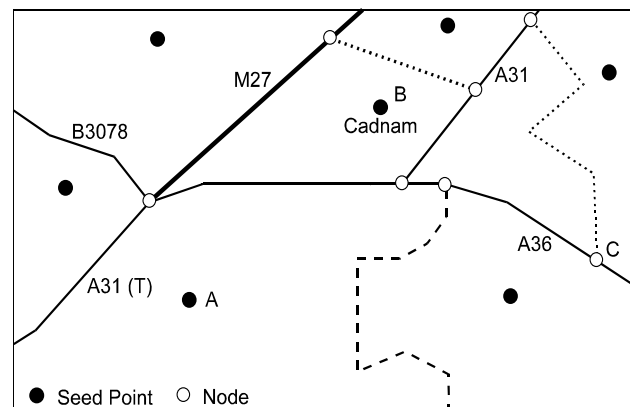

Figure 2.2b: the same geometric structure as map features.



Lines and points from the geometric structure become features when a meaning, the feature code, has been added – for example, roads are created from lines, or settlements from points.

In figure 2.2b:

- Point A is a seed point that has attached to it a feature code, identifying it – in this case – as a woodland area.
- Point B is a seed point with a feature code that identifies it as an urban area; the seed will also carry its distinctive name attribute – Cadnam.
- Point C is a special case of a point feature that shares a unique coordinate junction between intersecting features. These points are not generally found within the data supplied.

Some lines and points are common to more than one map feature; as shown in figure 2.3c the area – Cadnam – shares its boundaries with the M27, A31(T), A31 and A36.

Figure 2.3a: separate storage of overlapping features.

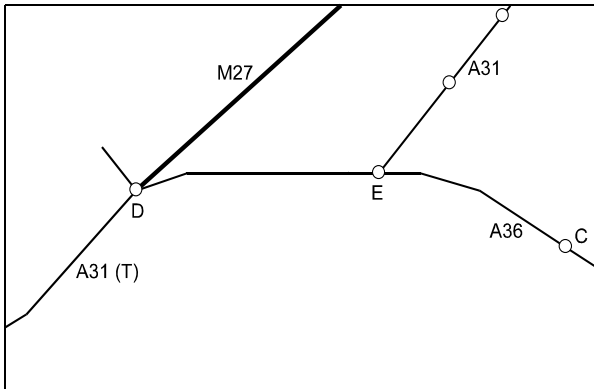
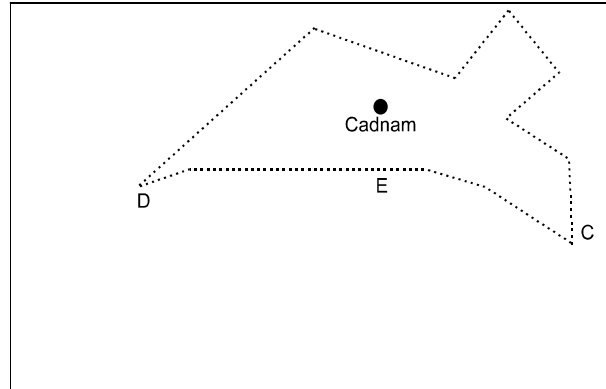
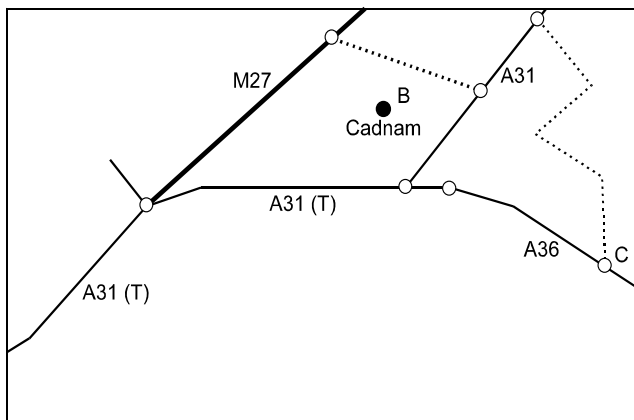

Figure 2.3b: separate storage of overlapping features.



The common line (D–E) to the A31(T) and the settlement polygon, and the common line (E–C) to the A36 and the settlement polygon, each represent two lines. The geometry of each overlapping feature is stored separately in the data as indicated in figures 2.3a, 2.3b and 2.3c.

Figure 2.3c: overlapping features



NOTE: within these examples, road numbers are attributes of the features.

Feature position

The geometry of map features is defined in terms of coordinates. All coordinates used in Strategi are based on the National Grid coordinate referencing system, and are quoted to a 1 m resolution.

Due to limitations of the map scale, features are generalised to give the clearest representation of the real ground position. Certain features will take priority over others according to their importance and their contribution to the usefulness of the map data. As a result of this process, features may be omitted, moved, emphasised or simplified to aid clarity and avoid unnecessary clutter.

The [National Grid](#) as it applies to Strategi is explained more fully in the user guide.

Feature attribute data

An attribute is the descriptive characteristic of a feature, that is, a non-spatial element.

The geometry of the lines and points within the data would be meaningless unless they are assigned some distinguishing property. In Ordnance Survey map data terms, an attribute can be a numerical feature code, or a distinctive name or number such as 'Birmingham' or 'M40'.

Information relevant to NTF

Coordinates

Coordinate values and the number of coordinate pairs in a feature are transferred in the two-dimensional geometry record [GEOMETRY1].

All coordinates within the data are expressed as strings of seven numeric characters. Leading zeros are present to complete the seven characters.

All coordinates are full National Grid coordinates, measured from the absolute origin (0,0).

Bearings

Bearings are transferred in the {ORIENT} field of the node record [NODEREC].

Bearings are National Grid bearings, in degrees, measured clockwise from grid north.

The start of line bearing, indicated by a value of 1 in the {DIR} field of the node record [NODEREC], is the bearing of the first segment of the line. The direction is from the start of the line to the next pair of coordinates or, if there are only two coordinate pairs, from the start to the end of the line.

The end of line bearing, indicated by a 2 in the {DIR} field, is the bearing of the last segment of the line. The direction is from the end of the feature to the last-minus-one pair of coordinates.

Attribute codes

Attribute codes provide supplementary information on a feature, providing such qualifying information as feature code, feature name, orientation and so on.

In NTF, the structure of user-defined attributes is described in the attribute description record [ATTDESC].

The actual attribute detail of a record is written in the attribute record [ATTREC].

Transfer set structure

The beginning of each transfer set is structured with the following introductory, or leading, records:

- Database header record [DBHREC]: this gives details of:
 - the database name;
 - NTF release date;
 - feature classification table name; and
 - release date that applies to the whole of the transfer set.
- Attribute description record [ATTDESC]: this lists and gives a description of the attributes that can be applied to features within the transfer set.
- Feature classification record [FEATCLASS]: this lists and gives descriptions of all possible feature codes for the transfer set.

These introductory records are followed by the data requested by you.

This section consists of two parts:

- Section header record [SECHREC]: this gives the National Grid coordinates of the section and on unformatted media, informs you that a new section is starting; and
- Section body: this comprises all the features within the section.

General

The following are the record definitions for the transfer of Strategi data in NTF:

- volume header record [VOLHDREC];
- database header record [DBHREC];
- attribute description record [ATTDESC];
- feature classification record [FEATCLASS];
- section header record [SECHREC];
- section body (see [Point and line features](#) below):
 - name detail; and
 - node detail
- volume terminator record [VOLTERM].

Section body

This comprises all the features within the file that correspond to the feature types selected by you.

Point and line features

Point feature

Each point feature is depicted by the use of the following records:

	Description in NTF
POINT RECORD	[POINTREC]
GEOMETRY RECORD	[GEOMETRY1]
ATTRIBUTE RECORD	[ATTREC]

Line feature

Each line feature is depicted by the use of the following records:

	Description in NTF
LINE RECORD	[LINEREC]
GEOMETRY RECORD	[GEOMETRY1]
GEOMETRY CONTINUATION RECORDS	
ATTRIBUTE RECORDS	[ATTREC]

Geometry records

Geometry records contain the coordinate position(s) in metres of the feature. Point features contain one coordinate pair; line features contain two or more coordinate pairs. Geometry continuation records are used where required. {X_COORDS}, {Y_COORDS} and {QPLAN} are treated as separate fields.

Name detail

Each cartographically-positioned name is depicted by the use of the following records:

	Description in NTF
TEXT RECORD	[TEXTREC]
TEXT POSITION RECORD	[TEXTPOS]
TEXT REPRESENTATION RECORD	[TEXTREP]
GEOMETRY RECORD	[GEOMETRY1]
ATTRIBUTE RECORD	[ATTREC]

Records

Text details are only given when a name has been cartographically positioned. The attribute record [ATTREC] contains the definitive name and is pointed to by the text record [TEXTREC].

The text record points to the attribute record [ATTREC] and also points to the text position record [TEXTPOS].

The text position record refers back to the text record and points to the geometry record, containing the coordinates of the digitised position. The text position record also points to the text representation record [TEXTREP], which contains the standard digitising position and orientation of the text.

All other names are held as attributes only.

Node detail

Node feature

Each node feature is depicted by the use of the following records:

	Description in NTF
NODE RECORD	[NODEREC]
NODE CONTINUATION RECORD	
GEOMETRY RECORD	[GEOMETRY1]
POINT RECORD	[POINTREC]
ATTRIBUTE RECORD	[ATTREC]

Records

Node record transfers details of the bearings and number of lines that meet at a point or node.

The node record contains references to each line record that meets at that node and to the geometry record. The geometry record is referenced by the point records containing the feature attributes of the node.

Feature code 5200 node exists where road features finish at the same point.

The node record can contain details of up to ten line features that meet at a node.

It is important to note that, although the node record contains references to its appropriate point and line features, the point and line features do not contain references to the node.

Data supply structure

Record size

NTF data is written to the output device in variable length records, with a maximum record length of 80 characters, which includes {CONT_MARK} and {EOR}.

Record terminator {EOR}

The end-of-record terminator is the per cent (%) (ASCII 37) character.

Formatted media (transfer set less than media capacity)

01	VOLUME HEADER RECORD	01
02	DATABASE HEADER RECORD	
40	ATTRIBUTE DESCRIPTION RECORD	
05	FEATURE CLASSIFICATION RECORD	
07	SECTION HEADER RECORD	
	Tile 1 data	
99	VOLUME TERMINATION RECORD	
01	VOLUME HEADER RECORD	01
02	DATABASE HEADER RECORD	
40	ATTRIBUTE DESCRIPTION RECORD	
05	FEATURE CLASSIFICATION RECORD	
07	SECTION HEADER RECORD	
	Tile 2 data	
99	VOLUME TERMINATION RECORD	
	and so on	
	Tile n data	
99	VOLUME TERMINATION RECORD	

Attribute codes relevant to NTF and DXF are described more fully in [chapter 2](#) for NTF and in [chapter 4](#) of the technical specification for DXF.

Feature codes



Each feature is classified by means of a feature code (FC). These feature codes are allocated when each feature is initially interpreted and captured from the map base. Thus an A road dual carriageway is distinguished by the feature code allocated to it from a B road single carriageway and other kinds of line feature.

Each feature is classified as belonging to a specific feature layer. These layers range in value from G8060570 to G8065901, using the *Layer Naming Convention for CAD in the Construction Industry Version 2*, which is based upon the guidelines laid down in BS 1192: Part 5 – *Guide for structuring of computer graphic information*. These feature layers are listed in [chapter 8](#).

An additional text feature code for layout of footnotes is included. This feature code is listed in [chapter 8](#).

In order to display the attributes stored as extended entity data, the following two scripts are required. These two files – *Showeed.lsp* and *Showeed.dcl* – are available to download from the Ordnance Survey website and should be placed in a directory in the AutoCAD preferences search string. This should include the directory containing the map data files in DXF.

To utilise the scripts, type the following at the AutoCAD command line prompt within a drawing session:

```
AutoCAD:      (load "showeed")
AutoCAD:      eedd
```

Selecting a map feature will now display the allied attributes of that feature in a dialogue box. To interrogate other features, the *Re-Select* option on the user dialogue box should be chosen. The *Cancel* option will return the user to a normal AutoCAD session.

If the *eedd* command is repeated at the command prompt, the facility will again be available to the user.

The visibility of extended entity data to software other than AutoCAD release 12 will be constrained by the functionality of those individual software applications.



Each feature is classified as belonging to a specific feature code. These feature codes are listed in [chapter 6](#).

These differences in the data are inferred during translation from Ordnance Survey's internal data format to the required customer transfer format.

Names as attributes

The criteria for names attribute attachment are as follows:

Rivers and roads each portion of the line, where named in the data.

Place names a chosen seed point in the urban area.

Other names free-standing seed points.

Not all stored data is named.

It is possible, with appropriate software, for users to add other names or values of their own choice as attributes of features.

Over codes

The *over* code allows you to give priority to features that go over other features. This code can apply to roads, canals and railways.

Attribute codes for Strategi

Attributes that are used in the supply of Strategi are:

Abbreviation	Description	Explanation and examples
CM	County name	Administrative area county name, for example, <i>KENT COUNTY</i>
DE	Date	The date of the last amendment, for example, <i>20001128</i>
DN	District name	Administrative area district name, for example, <i>THANET DISTRICT</i>
FE	Ferry access	Shows method of vehicular access to ferry, for example, roll-on roll-off
FF	Ferry from	Shows ferry departure location
FI	Ferry time	Shows normal crossing time
FM	Feature name	Feature name, for example, <i>Southampton, River Test</i>
FP	Ferry type	Shows type of ferry, for example, boat or catamaran
FR	Ferry restrictions	For example, all year or seasonal
FT	Ferry to	Shows ferry destination
GS	GIS	Intelligence unique identifier, for example, <i>33596</i>
HI	Height – imperial	Shows height as an imperial measurement
HM	Height – metric	Shows height as a metric measurement
LO	Location	Identifies location, for example, on motorway, primary/non-primary route
NU	Numbered feature	Numbered feature, for example, <i>M27</i> or junction number
OR	Orientation	Used to describe the orientation of a point feature from grid east, anticlockwise. If absent, the feature is not deemed to have an orientation.
OW	Owner	Property owner, for example, <i>ENGLISH HERITAGE.</i>
RB	Point (bounded)	Point bounded by line features, for example, a lake
RJ	Restriction north	Restricted junction – northbound
RL	Restriction south	Restricted junction – southbound
RM	Restriction east	Restricted junction – eastbound
RQ	Restriction west	Restricted junction – westbound
RU	Point (unbounded)	Point not bounded by line features, for example, <i>SOUTH DOWNS</i>
RW	Restriction clockwise	Restricted junction – clockwise
RZ	Restriction anticlockwise	Restricted junction – anticlockwise
TX	Text	Graphic text associated with a name
UE	Usage	Indicates status, for example, under construction, open 24 hours and so on
UN	Unitary name	Administrative area unitary authority name, for example, <i>FIFE</i>

Attribute values for Strategi

Feature	Code	Attribute	Value	Value description
Park and ride	5806	UE	1	Operates all year with a minimum open time Monday–Saturday
Park and ride	5806	UE	2	Seasonal or Saturday only
Service station (24 hour)	5360, 5361	UE	3	Open 24 hours, under construction
Service station (24 hour)	5360, 5361	UE	4	Open 24 hours, operational
Service station (non-24 hour)	5392	UE	5	Not open 24 hours, under construction
Service station (non-24 hour)	5392	UE	6	Not open 24 hours, operational
Service station (24 hour)	5360, 5361	LO	1	Motorway
Service station (24 hour)	5360, 5361	LO	2	Primary route
Service station (24 hour)	5360, 5361	LO	3	A-class road
Service station (non-24 hour)	5392	LO	2	Primary route
Service station (non-24 hour)	5392	LO	3	A-class road
Settlement attribute points	5413, 5416, 5427	LO	4	Primary route destination
Settlement attribute points	5413, 5416, 5427	LO	5	Non-primary route destination
Airport/heliport	5839, 5840, 5841, 5845	UE	7	GB only
Airport/heliport	5839, 5840, 5841, 5845	UE	8	European
Airport/heliport	5839, 5840, 5841, 5845	UE	9	Worldwide

NTF feature codes for Strategi

Feature code	Feature name	NTF abbreviated feature name	Graphic type	NTF attribute	Value
5006	Non-primary route destination town graphic text	NPR Destination Town Graphic Text	Text	DE, TX	-
5016	Other graphic text	Other Graphic Text	Text	DE, TX	-
5020	Water feature graphic text	Water Feature Graphic Text	Text	DE, TX	-
5025	Primary route destination city graphic text	PRD City Graphic Text	Text	DE, TX	-
5026	Non-primary route destination city graphic text	NPR Destination City Graphic Text	Text	DE, TX	-
5031	Motorway number graphic text	Motorway Number Graphic Text	Text	DE, TX	-
5032	Primary route number graphic text	Primary Route Number Graphic Text	Text	DE, TX	-
5033	A road number graphic text	A Road Number Graphic Text	Text	DE, TX	-
5034	B road number graphic text	B Road Number Graphic Text	Text	DE, TX	-
5036	Road distance mileage (motorway) graphic text	Road Distance (Motorway) Graphic Text	Text	DE, TX	-
5037	Road distance (primary and A) graphic text	Road Distance (Primary & A) Graphic Text	Text	DE, TX	-
5038	Toll graphic text	Toll Graphic Text	Text	DE, TX	-
5039	Ferry annotation graphic text	Ferry Annotation Graphic Text	Text	DE, TX	-

Feature code	Feature name	NTF abbreviated feature name	Graphic type	NTF attribute	Value
5040	Non-primary route village graphic text	NPR Village Graphic Text	Text	DE, TX	-
5041	Primary route destination town graphic text	PRD Town Graphic Text	Text	DE, TX	-
5042	Motorway junction number (full access) graphic text	Motorway Junc No (Full Access) Graphic Text	Text	DE, TX	-
5043	Motorway junction number (limited access) graphic text	Motorway Junc No (Ltd Access) Graphic Text	Text	DE, TX	-
5044	Tourist feature graphic text	Tourist Feature Graphic Text	Text	DE, TX	-
5045	National trail, long distance path and route graphic text	Long Distance Footpath Graphic Text	Text	DE, TX	-
5046	National park/forest park graphic text	National Park/Forest Park Graphic Text	Text	DE, TX	-
5048	Services graphic text	Services text	Text	DE, TX	-
5049	Primary route destination village graphic text	PRD Village Graphic Text	Text	DE, TX	-
5060	Geographic area graphic text	Geographical Area Graphic Text	Text	DE, TX	-
5061	Large hills, ranges and summits graphic text	Large Hills and Ranges Graphic Text	Text	DE, TX	-
5062	Named hills, islands and rocks graphic text	Hills, Islands and Rocks Graphic Text	Text	DE, TX	-
5081	Roman antiquity graphic text (AD 43–AD 420)	Roman Antiquity Graphic Text	Text	DE, TX	-
5082	Non-Roman antiquities graphic text	Non-Roman Antiquities Graphic Text	Text	DE, TX	-
5090	Spot height values	Spot Height Value Graphic Text	Text	DE, TX	-
5107	Road distance marker (primary & A)	Road Distance Marker (Primary & A)	Point	DE, OR	-
5108	Road distance marker (motorway)	Road Distance Marker (Motorway)	Point	DE, OR	-
5109	Dual junction graphic text divider line	Dual Junction Graphic Text Divider Line	Point	DE, OR	-
5110	Coastline	Coastline	Line	DE	-
5115	Sea seed below mean high water	Sea Seed below Mean High Water	Point	DE, RU	-
5120	Foreshore (sand, outer limit)	Foreshore (Sand, outer limit)	Line	DE	-
5121	Foreshore (sand) seed	Foreshore (Sand) Seed	Point	DE, RB	-
5122	Foreshore (other) and offshore rocks exposed at mean low water, outer limit)	Foreshore (Other, outer limit)	Line	DE	-
5123	Foreshore (other) and offshore rocks exposed at mean low water seed	Foreshore (Other) Seed	Point	DE, RB	-
5140	Lighthouse (in use)	Lighthouse (in use)	Point	GS, FM, DE	-
5141	Lightship	Lightship	Point	GS, FM, DE	-
5142	Lighthouse (disused)	Lighthouse (disused)	Point	GS, FM, DE	-
5200	Unspecified node	Unspecified node			
5211	River (primary), source	River (Primary), Source	Line	FM, DE	-
5212	River (primary), middle	River (Primary), Middle	Line	FM, DE	-
5213	River (primary), lower	River (Primary), Lower	Line	FM, DE	-
5221	River (secondary), source	River (Secondary), Source	Line	FM, DE	-
5222	River (secondary), middle	River (Secondary), Middle	Line	FM, DE	-

Feature code	Feature name	NTF abbreviated feature name	Graphic type	NTF attribute	Value
5230	River (other and drains)	River (Other and Drains)	Line	DE	-
5240	Canal	Canal	Line	FM, DE	-
5241	Canal tunnel	Canal Tunnel	Line	FM, DE	-
5242	Canal (over)	Canal (Over)	Line	FM, DE	-
5250	Inland water (outer limit)	Inland Water (outer limit)	Line	DE	-
5251	Inland water seed	Inland Water Seed	Point	DE, RB	-
5300	Motorway (under construction)	Motorway (U/C)	Line	DE, NU	-
5301	Motorway (under construction, over)	Motorway (U/C, over)	Line	DE, NU	-
5302	Primary route, dual carriageway (under construction)	Primary Route, DC (U/C)	Line	DE, NU	-
5303	Primary route, dual carriageway (under construction, over)	Primary Route, DC (U/C, over)	Line	DE, NU	-
5304	Primary route, single carriageway (under construction)	Primary Route, SC (U/C)	Line	DE, NU	-
5305	Primary route, single carriageway (under construction, over)	Primary Route, SC (U/C, over)	Line	DE, NU	-
5306	A road, dual carriageway (under construction)	A Road, DC (U/C)	Line	DE, NU	-
5307	A road, dual carriageway (under construction, over)	A Road, DC (U/C, over)	Line	DE, NU	-
5308	A road, single carriageway (under construction)	A Road, SC (U/C)	Line	DE, NU	-
5309	A road, single carriageway (under construction, over)	A Road, SC (U/C, over)	Line	DE, NU	-
5310	Motorway	Motorway	Line	DE, NU	-
5311	Motorway, planned	Motorway, Planned	Line	DE, NU	-
5312	Motorway (over)	Motorway (over)	Line	DE, NU	-
5313	Motorway tunnel	Motorway Tunnel	Line	DE, NU	-
5314	Road tunnel (end symbol)	Road Tunnel (end symbol)	Point	DE, OR	-
5320	Primary route, dual carriageway	Primary Route, D/C	Line	DE, NU	-
5321	Primary route, dual carriageway planned	Primary Route, D/C Planned	Line	DE, NU	-
5322	Primary route, dual carriageway (over)	Primary Route, D/C (over)	Line	DE, NU	-
5323	Primary route, single carriageway	Primary Route, S/C	Line	DE, NU	-
5324	Primary route, single carriageway planned	Primary Route, S/C Planned	Line	DE, NU	-
5325	Primary route, single carriageway (over)	Primary Route, S/C (over)	Line	DE, NU	-
5326	Primary route, narrow	Primary Route, Narrow	Line	DE, NU	-
5327	Primary route, narrow (over)	Primary Route, Narrow (over)	Line	DE, NU	-
5330	A road, dual carriageway	A Road, D/C	Line	DE, NU	-
5331	A road, dual carriageway planned	A Road, D/C Planned	Line	DE, NU	-
5332	A road, dual carriageway (over)	A Road, D/C (over)	Line	DE, NU	-
5333	A road, single carriageway	A Road, S/C	Line	DE, NU	-
5334	A road, single carriageway planned	A Road, S/C Planned	Line	DE, NU	-
5335	A road, single carriageway (over)	A Road, S/C (over)	Line	DE, NU	-

Feature code	Feature name	NTF abbreviated feature name	Graphic type	NTF attribute	Value
5336	A road, narrow	A Road, Narrow	Line	DE, NU	-
5337	A road, narrow (over)	A Road, Narrow (over)	Line	DE, NU	-
5340	B road, dual carriageway	B Road, D/C	Line	DE, NU	-
5342	B road, dual carriageway (over)	B Road, D/C (over)	Line	DE, NU	-
5343	B road, single carriageway	B Road, S/C	Line	DE, NU	-
5345	B road, single carriageway (over)	B Road, S/C (over)	Line	DE, NU	-
5346	B road, narrow	B Road, Narrow	Line	DE, NU	-
5347	B road, narrow (over)	B Road, Narrow (over)	Line	DE, NU	-
5350	Minor road over 4 m wide	Minor Road over 4 metres wide	Line	DE	-
5351	Minor road over 4 m wide (over)	Minor Road over 4 metres wide (over)	Line	DE	-
5353	Minor road over 4 m wide tunnel	Minor Road over 4 metres wide Tunnel	Line	DE	-
5355	Roundabout (primary route, dual carriageway)	Roundabout (Primary Route, D/C)	Point	DE	-
5356	Roundabout (A road, dual carriageway)	Roundabout (A Road, D/C)	Point	DE	-
5357	Roundabout (B road, dual carriageway)	Roundabout (B Road, D/C)	Point	DE	-
5358	A road tunnel	A Road Tunnel	Line	DE, NU	-
5359	B road tunnel	B Road Tunnel	Line	DE, NU	-
5360	Service station (full access – 24 hour)	Service Station (Full Access)	Point	GS NU UE LO DE OR	- - 3, 4 1, 2, 3 -
5361	Service station (limited access)	Service Station (Limited Access)	Point	GS NU UE LO RJ RM RL RQ RW RZ DE OR	- - 3, 4 1, 2, 3 - - - - - - - -
5370	Motorway junction (full access)	Motorway Junction (Full Access)	Point	GS, DE, NU	-
5371	Motorway junction (limited access)	Motorway Junction (Limited Access)	Point	GS, RJ, RM, RL, RQ, RW, RZ, DE NU	-
5372	Motorway junction (under construction)	Motorway Junction (U/C)	Point	GS, DE, NU	-
5373	Primary route tunnel	Primary Route Tunnel	Line	DE, NU	-
5374	Roundabout (minor road over 4 m wide)	Roundabout (Minor Road over 4m wide)	Point	DE	-
5375	Roundabout (primary route, single carriageway)	Roundabout (Primary Route, S/C)	Point	DE	-
5376	Roundabout (A road, single carriageway)	Roundabout (A Road, S/C)	Point	DE	-
5377	Roundabout (B road, single carriageway)	Roundabout (B Road, S/C)	Point	DE	-

Feature code	Feature name	NTF abbreviated feature name	Graphic type	NTF attribute	Value
5378	Multilevel junction (under construction)	Multi-level Junction (U/C)	Point	GS, DE	-
5379	Multilevel junction (full access)	Multi-level Junction (Full Access)	Point	GS, NU, DE	-
5380	Gradient 1 in 7 (14%) or steeper on primary, A and B roads	Gradient 1 In 7 or steeper	Point	GS, DE, OR	-
5381	Roundabout (under construction)	Roundabout (U/C)	Point	DE	-
5382	Toll bar	Toll Bar	Point	DE, OR	-
5384	Other track or road	Other Track or Road	Line	DE	-
5385	Other track or road (over)	Other Track or Road (over)	Line	DE	-
5389	Multilevel junction (limited access)	Limited Multi-level Junction	Point	GS, NU, RJ, RM	-
5390	Vehicular ferry route	Vehicular Ferry Route	Line	GS, FE, FR, FP, FF, FT, FI, DE	-
5392	Service Station (non 24 hour)	Non 24 hour Services	Point	GS, NU, UE, LO, DE, OR	5, 6, 2, 3
5393	Ferry route link	Ferry Route Link	Line	GS, FE, FR, FP, FF, FT, FI, DE	-
5397	100 km accentuated grid line	100 km Accentuated Grid Line	Line		-
5398	10 km grid line	10 km Grid Line	Line		-
5403	Dead end road	Dead-End Road gen under 4m wide	Line	DE	-
5404	Dead end road (over)	Dead-End Road gen under 4m wide (over)	Line	DE	-
5405	Minor road under 4 m wide	Minor Road under 4 metres wide	Line	DE	-
5406	Minor road under 4 m wide (over)	Minor Road under 4 metres wide (over)	Line	DE	-
5407	Minor road under 4 m wide tunnel	Minor Road under 4 metres wide Tunnel	Line	FM, DE	-
5408	Roundabout (minor road under 4 m wide)	Roundabout (Minor Road under 4m wide)	Point	DE	-
5413	Town attribute point	Town Attribute Point	Point	FM CM or UN DE, LO	- 4, 5 -
5416	Village attribute point	Village Attribute Point	Point	FM, DE CM or UN LO	- - 4, 5
5419	Landmark attribute point	Landmark Attribute Point	Point	FM CM or UN DE	- - -
5420	Large urban area (outer limit)	Large Urban Area (outer limit)	Line	DE	-
5421	Large urban area seed	Large Urban Area Seed	Point	DE, RB	-
5422	Small urban area (outer limit)	Small Urban Area (outer limit)	Line	DE	-
5423	Small urban area seed	Small Urban Area Seed	Point	DE, RB	-
5427	City attribute point	City Attribute Point	Point	FM, DE CM or UN LO	- - 4, 5
5490	Inland water (inner limit)	Inland Water (inner limit)	Line	DE	-

Feature code	Feature name	NTF abbreviated feature name	Graphic type	NTF attribute	Value
5491	Wood/forest (inner limit)	Wood/Forest (inner limit)	Line	DE	-
5492	Large urban area (inner limit)	Large Urban Area (inner limit)	Line	DE	-
5493	Small urban area (inner limit)	Small Urban Area (inner limit)	Line	DE	-
5494	Foreshore (sand, inner limit)	Foreshore (Sand, inner limit)	Line	DE	-
5495	Foreshore (other) and offshore rocks exposed at mean low water, inner limit	Foreshore (Other, inner limit)	Line	DE	-
5510	Railway, standard gauge	Railway, Standard Gauge	Line	DE	-
5511	Railway, standard gauge (over)	Railway, Standard Gauge (over)	Line	DE	-
5512	Railway, narrow gauge	Railway, Narrow Gauge	Line	DE	-
5513	Railway, narrow gauge (over)	Railway, Narrow Gauge (over)	Line	DE	-
5514	Railway tunnel	Railway Tunnel	Line	DE	-
5519	Railway, standard gauge (under construction)	Railway, Standard Gauge (U/C)	Line	DE	-
5520	Railway station	Railway Station	Point	GS, FM, DE	-
5521	Rapid transit station	Rapid Transit Station	Point	GS, FM, DE	-
5522	Rapid transit line	Rapid Transit Line	Line	DE	-
5523	Rapid transit line (over)	Rapid Transit Line (over)	Line	DE	-
5524	Rapid transit tunnel	Rapid Transit Tunnel	Line	DE	-
5525	Rapid transit line (U/C)	Rapid Transit Line (U/C)	Line	DE	-
5530	Level crossing on classified road	Level Crossing on Classified Road	Point	GS, DE, OR	-
5531	Level crossing on unclassified road	Level Crossing on Unclassified Road	Point	GS, DE, OR	-
5610	Wood/forest (outer limit)	Wood/Forest (outer limit)	Line	DE	-
5611	Wood/forest seed	Wood/Forest Seed	Point	DE, RB	-
5612	Marsh	Marsh	Point	DE	-
5620	Geographic area attribute point	Geographic Area Attribute Point	Point	FM, DE, RU	-
5621	Island area attribute point	Island Area Attribute Point	Point	FM, DE, RB	-
5710	National boundary	National Boundary	Line	DE	-
5715	National primary attribute point	National Primary Attribute Point	Point	FM, DE, RU	-
5720	County boundary	County Boundary	Line	DE	-
5721	County name graphic text	County Name Graphic Text	Text	DE, TX	-
5725	County primary attribute point	County Primary Attribute Point	Point	CM, DE, RU	-
5730	District boundary	District Boundary	Line	DE	-
5731	District name graphic text	District Name Graphic Text	Text	DE, TX	-
5733	District primary attribute point	District Primary Attribute Point	Point	DN, CM, DE, RU	-
5734	Administrative detached attribute point	Administrative Detached Attribute Point	Point	DN CM or UN, DE, RB	-
5740	Unitary authority boundary	Unitary Boundary	Line	DE	-
5741	Unitary authority name graphic text	Unitary Name Graphic Text	Text	DE, TX	-
5744	Unitary authority primary attribute point	Unitary Primary Attribute Point	Point	UN, DE, RU	-
5750	Associated area boundary	Associated Area Boundary	Line	DE	-
5805	Camping and caravanning combined site	Camping and Caravanning Combined Site	Point	GS, DE	-
5806	Park and ride	Park and Ride	Point	GS UE DE	- 1, 2 -
5810	Roman road	Roman Road	Line	FM, DE	-

Feature code	Feature name	NTF abbreviated feature name	Graphic type	NTF attribute	Value
5812	Antiquity line detail (dyke, wall and so on)	Antiquity Line Detail (dyke, wall, etc)	Line	FM, DE	-
5815	Hill fort	Hill Fort	Point	GS, FM, DE	-
5816	Battlefield	Battlefield	Point	GS, FM, DE	-
5820	National park/forest park	National Park/Forest Park	Line	DE	-
5821	National park/forest park attribute point	National Park/Forest Park Attrib Point	Point	FM, DE, RB	-
5825	National trail, long distance path and route	Long Distance Footpath	Line	FM, DE	-
5835	Television, radio mast or tower	Television, Radio Mast or Tower	Point	GS, DE	-
5837	Telephone dot	Telephone Dot	Point	DE	-
5838	Landmark/antiquity dot	Landmark/Antiquity dot	Point	GS, FM, DE	-
5839	Airport with customs but no scheduled flights	Airport Non Sch with Perm cust facility	Point	GS, FM, CM or UN, UE, DE	7,8,9
5840	Airport without customs facilities	Airport Sch without customs facility	Point	GS, FM, CM or UN, UE, DE	7,8,9
5841	Airport with permanent customs facilities where no prior notification is necessary	Airport Sch with Perm customs facility	Point	GS, FM, CM or UN, UE, DE	7,8,9
5843	Wind-powered generator	Wind Powered Generator	Point	GS, DE	-
5844	Windmill	Windmill	Point	GS, DE	-
5845	Heliport	Heliport	Point	GS, FM, UE, DE	-
5847	Public telephone	Public Telephone	Point	DE	-
5849	Motoring organisation telephone	Motoring Organisation Telephone	Point	DE	-
5851	Theme park (open to the public)	Theme Park (open to the public)	Point	GS, FM, DE	-
5860	Abbey, cathedral, priory (open to the public)	Abbey, Cath, Priory (open to the public)	Point	GS, FM, OW DE	-
5861	Camp site	Camp Site	Point	GS, DE	-
5862	Caravan site	Caravan Site	Point	GS, DE	-
5863	Golf course	Golf Course	Point	GS, DE	-
5864	Museum (open to the public)	Museum (open to the public)	Point	GS, FM, OW, DE	-
5865	Picnic site	Picnic Site	Point	GS, DE	-
5866	Tourist information centre (open all year)	Tourist Info Centre (open all year)	Point	GS, DE	-
5867	Country park (open to the public)	Country Park (open to the public)	Point	GS, FM, DE	-
5868	Youth hostel	Youth Hostel	Point	GS, DE	-
5869	Nature or forest trail	Nature Or Forest Trail	Point	GS, DE	-
5870	Zoo (open to the public)	Zoo (open to the public)	Point	GS, FM, DE	-
5871	Preserved railway	Preserved Railway	Point	GS, FM, DE	-
5873	Craft centre (open to the public)	Craft Centre (open to the public)	Point	GS, FM, DE	-
5874	Wildlife centre (open to the public)	Wildlife Centre (open to the public)	Point	GS, FM, DE	-
5875	Aquarium (open to the public)	Aquarium (open to the public)	Point	GS, FM, DE	-
5876	Cave (open to the public)	Cave (open to the public)	Point	GS, DE	-

Feature code	Feature name	NTF abbreviated feature name	Graphic type	NTF attribute	Value
5877	Castle (open to the public)	Castle (open to the public)	Point	GS, FM, OW, DE	-
5878	Historic house (open to the public)	Historic House (open to the public)	Point	GS, FM, OW, DE	-
5879	Motor racing circuit	Motor Racing Circuit	Point	GS, FM, DE	-
5880	Nature reserve	Nature Reserve	Point	GS, FM, OW, DE	-
5881	Viewpoint (limited)	Viewpoint (Limited)	Point	GS, DE, OR	-
5882	Viewpoint (360°)	Viewpoint (360°degrees)	Point	GS, DE	-
5883	Other tourist attraction (open to the public)	Other Tourist Attract (open to the public)	Point	GS, FM, OW, DE	-
5884	Ski slope	Ski Slope	Point	GS, DE	-
5885	Racecourse	Racecourse	Point	GS, FM, DE	-
5886	Garden (open to the public)	Garden (open to the pub)	Point	GS, FM, OW, DE	-
5887	Ferry boat	Ferry Boat	Point	DE	-
5888	Ferry hovercraft	Ferry Hovercraft	Point	DE	-
5889	Tourist information centre (seasonal)	Tourist Info Centre (seasonal)	Point	GS, DE	-
5890	Ferry box outline	Ferry Box Outline	Line	DE	-
5892	Ferry catamaran	Ferry Catamaran	Point	DE	-
5901	Spot height dots	Spot Height Dot	Point	HI, HM, DE, GS	

Conventions used in this technical specification

Certain conventions are adopted as an aid to interpretation. In some cases the convention is dropped where the context is self-evident.

[] Square brackets are placed around record names, for example, [VOLHDREC].

{ } A pair of braces denote field names, for example, {REC_DESC} is the record descriptor field.

[] 90 A two-digit number following square brackets denotes the record descriptor, which uniquely identifies the record name between the brackets.

<S> This is the space character (ASCII code 32).

<3S> This denotes three successive space characters.

% The percentage character (ASCII code 37).

Version management

The product version number and the release number are specified in the database header record [DBHREC], as supplied in NTF.

Product version

Each version of Stragegi is defined by a unique **product version number** and relates to the specification of the data being supplied. The product version number takes the form **xx.yy**, where **xx** is the major product number and **yy** is the minor change number. Thus version 02.04 would indicate that this is the major product version 02, and that this is the fourth minor amendment to the product specification.

This technical specification reflects the product specification current at the date of this technical specification, for example, *Stragegi_02.00*. The effective date of this product specification is May 2010 and is indicated by the {FCDATE} field of the database header record [DBHREC].

Product release

The release number takes the form *xx.yy*, where *xx* is the sequential release within a year and *yy* is the year of the release. Thus release 01.01 would indicate that this is the first data release in 2001 and is indicated by the {DBNAME} field of the database header record [DBHREC].

Product releases do not necessarily include a change of product version (specification).

NTF version

The current version is NTF v2.0 Level 3 and will be supplied until further notice. The NTF version is indicated by the {NTFVER} field of the volume header record [VOLHDREC]. The effective date of the definition of NTF v2.0 in Strategi is 15 May 1992 and is indicated by the {DDATE} field of the database header record [DBHREC].

Chapter 3 Record structures for the transfer of Strategi in NTF

NTF record list

This list comprises the valid record types used in the Strategi NTF transfer set.

Descriptor	Description	Record name
01	Volume header record – defines the donor and data type	[VOLHDREC]
02	Database header record – transfers data about the database	[DBHREC]
05	Feature classification record – defines data classifications	[FEATCLASS]
07	Section header record – coordinate and structure types, unit scale, factors and so on	[SECHREC]
14	Attribute record – defines the attributes for line and point records	[ATTREC]
15	Point record – identifies the definition of node points	[POINTREC]
16	Node record – defines the topological relationship between links and nodes	[NODEREC]
21	Two-dimensional geometry record – defines the two-dimensional geometry for a link or node	[GEOMETRY1]
23	Line record – identifies the definition of a link	[LINEREC]
40	Attribute description record – defines attribute descriptions and their fields	[ATTDESC]
43	Text record – identifies the Text position record and Attribute record	[TEXTREC]
44	Text position record – identifies the Text representation record and Geometry record	[TEXTPOS]
45	Text representation record – defines the font, text height and digitised position	[TEXTREP]
99	Volume terminator record – defines the end of the transfer set	[VOLTERM]

Volume header record [VOLHDREC] 01

Field	Position	Format	Value example	Description
REC_DESC	01:02	A2	01	
DONOR	03:22	A20	ORDNANCE SURVEY<5S>	
RECIPIENT	23:42	A20	<20S>	Not used
TRANDATE	43:50	DATE	yyyymmdd	Date of processing
SERIAL	51:54	I4	0000	Not used
VOLNUM	55:56	I2		Volume number 01–99
NTFLEVEL	57:57	I1	3	
NTFVER	58:61	R4.2	0200	Version 2.0
NTFOR	62:62	A1	V	Variable length records
EOR	63:63	A1	%	(%) on unformatted media or
			<S>	default % on formatted media
DIVIDER	64:64	A1	\	Divider used in [ATTREC]
CONT_MARK	65:65	I1	0	No continuation record
EOR	66:66	A1	%	Record terminator

Record example:

01	ORDNANCE SURVEY		2001111200000130200V	\0%				
....1.....2.....3.....4.....5.....6.....7.....8
1234567890123456789012345678901234567890123456789012345678901234567890123456789012345678901234567890								
....

Template

Database header record [DBHREC] 02

Record 1

Field	Position	Format	Value example	Description
REC_DESC	01:02	A2	02	
DBNAME	03:22	A20	Strategi_01.02<6S>	Database name
DDNAME	23:42	A20	DEFAULT 02.00<7S>	
DDATE	43:50	DATE	19920515	Release date of NTF version being used
DDBASE	51:70	A20	<20S>	Not used
DDBDATE	71:78	DATE	00000000	Not used
CONT_MARK	79:79	I1	1	Continuation record follows
EOR	80:80	A1	%	Record terminator

Record 2

Field	Position	Format	Value example	Description
REC_DESC	01:02	A2	00	Continuation record
FCNAME	03:22	A20	Strategi_02.00<6S>	Data specification
FCDATE	23:30	DATE	20010901	Date of data specification
DQNAME	31:50	A20	<20S>	Not used
DQDATE	51:58	DATE	00000000	Not used
DATA_MODEL	59:60	I2	00	
CONT_MARK	61:61	I1	0	No continuation record
EOR	62:62	A1	%	Record terminator

Record example:

```
02Strategi_01.02      DEFAULT_02.00      19920515      000000001%
00Strategi_02.00      20010901      000000000000%
```

```
.... | .....1.... | .....2.... | .....3.... | .....4.... | .....5.... | .....6.... | .....7.... | .....8
123456789012345678901234567890123456789012345678901234567890123456789012345678901234567890
```

Template

Feature classification record [FEATCLASS] 05

Field	Position	Format	Value example	Description
REC_DESC	01:02	A2	05	
FEAT_CODE	03:06	A4	5310	Four-character feature code
CODE_COM	07:16	A10	<10S>	Not used
STCLASS	17:36	A20	<20S>	Not used
FEATDES	37:*	A*		Feature description
DIVIDER	*+1:~+1	A1	\	
CONT_MARK	*+2:~+2	I1	0	No continuation record
EOR	*+3:~+3	A1	%	Record terminator

* = variable integer.

Record example:

055310 Motorway\0%

....1....2....3....4....5....6....7....8
1234567890	1234567890	1234567890	1234567890	1234567890	1234567890	1234567890	1234567890	1234567890
....

Template

Section header record [SECHREC] 07

Record 1

Field	Position	Format	Value example	Description
REC_DESC	01:02	A2	07	
SECT_REF	03:12	A10	WALES<5s>	File name
COORD_TYP	13:13	I1	2	Rectangular
STRUC_TYP	14:14	I1	1	Vector
XYLEN	15:19	I5	00007	Seven-character coordinate fields
XY_UNIT	20:20	I1	2	Metres
XY_MULT	21:30	R10.3	0000001000	Default
Z_LEN	31:35	I5	00000	Not used
Z_UNIT	36:36	I1	0	Not used
Z_MULT	37:46	R10.3	0000001000	Default
X_ORIG	47:56	I10	0000000000	X coordinate of SW corner of unit (not used)
Y_ORIG	57:66	I10	0000000000	Y coordinate of SW corner of unit (not used)
Z_DATUM	67:76	I10	0000000000	Not used
CONT_MARK	77:77	I1	1	Continuation record follows
EOR	78:78	A1	%	Record terminator

Record 2

Field	Position	Format	Value example	Description
REC_DESC	01:02	A2	00	Continuation record
XMIN	03:12	I10	0000000000	
YMIN	13:22	I10	0000000000	
XMAX	23:32	I10	0000700000	
YMAX	33:42	I10	0001300000	
XY_ACC	43:47	R5.2	00000	Not used
Z_ACC	48:52	R5.2	00000	Not used
SURV_DATE	53:60	DATE	00000000	Not used
LAST_AMND	61:68	DATE	yyyymmdd	Date last amended
COPYRIGHT	69:76	DATE	yyyymmdd	Copyright date
CONT_MARK	77:77	I1	0	No continuation record
EOR	78:78	A1	%	Record terminator

Record example:

07WALES 21000072000000100000000000000010000000000000000000000000000001%
 00000000000000000000000000700000000130000000000000000000000020011112200111120%

....	1....	2....	3....	4....	5....	6....	7....	8
123456789012345678901234567890123456789012345678901234567890123456789012345678901234567890																
....	

Template

Attribute record [ATTREC] 14

All records will have FC and DE attributes. All others are optional.

Point record example:

Field	Position	Format	Value example	Description
REC_DESC	01:02	A2	14	
ATT_ID	03:08	I6	000001	

First attribute: feature code

Field	Position	Format	Value example	Description
VAL_TYPE	09:10	A2	FC	Feature code
VALUE	11:14	I4	5611	Woodland seed

Second attribute: Date

Field	Position	Format	Value example	Description
VAL_TYPE	15:16	A2	DE	Date
VALUE	17:24	DATE	YYYYMMDD	Date of last change

Third attribute: Bounded representative point

Field	Position	Format	Value example	Description
VAL_TYPE	25:26	A2	RB	Representative point
VALUE	27:27	A1	0	

Fourth attribute: Feature name

Field	Position	Format	Value example	Description
VAL_TYPE	28:29	A2	FM	Representative point
VALUE	30:*	A*	SHERWOOD FOREST	
DIVIDER	*:*	A1	\	
CONT_MARK	*:*	I1	0	No continuation record
EOR	*:*	A1	%	Record terminator

Would appear as:

14000001FC5611DE19980107RB0FMSHERWOOD FOREST\0%

Other examples of use of ATTREC for point features:

14000002FC5115DE000000000RU00%

This indicates {ATT_ID} 2, feature code 5115: the sea, which is a representative point of an unbounded area.

14000003FC5520DE19940718FMSOUTHAMPTON PARKWAY\0%

This indicates {ATT_ID} 3, feature code 5520: a railway station, with the proper name of Southampton Parkway.

14000015FC5380DE19990404OR08500%

This indicates {ATT_ID} 15, feature code 5380: a gradient 1 in 7 or steeper, symbol orientated at 85.0 degrees.

Attribute record: line

The following attributes are optional:

- FM: feature name
- NU: numbered feature

Line record example:

Field	Position	Format	Value example	Description
REC_DESC	01:02	A2	14	
ATT_ID	03:08	I6	000001	

First attribute: feature code

Field	Position	Format	Value example	Description
VAL_TYPE	09:10	A2	FC	Feature code
VALUE	11:14	I4	5810	Roman road

Second attribute: date

Field	Position	Format	Value example	Description
VAL_TYPE	15:16	A2	DE	Date
VALUE	17:24	DATE	YYYYMMDD	Date of last change

Third attribute: feature name

Field	Position	Format	Value example	Description
VAL_TYPE	25:26	A2	FM	Proper name
VALUE	27:*	A*	WATLING STREET	
DIVIDER	*.*	A1	\	
CONT_MARK	*.*	I1	0	No continuation record
EOR	*.*	A1	%	Record terminator
Field	Position	Format	Value example	Description
VAL_TYPE	25:26	A2	FM	Proper name
VALUE	27:*	A*	WATLING STREET	
DIVIDER	*.*	A1	\	
CONT_MARK	*.*	I1	0	No continuation record
EOR	*.*	A1	%	Record terminator
Field	Position	Format	Value example	Description
VAL_TYPE	25:26	A2	FM	Proper name
VALUE	27:*	A*	WATLING STREET	
DIVIDER	*.*	A1	\	
CONT_MARK	*.*	I1	0	No continuation record
EOR	*.*	A1	%	Record terminator

Would appear as:

14000001FC5810DE00000000FMWATLING STREET\0%

Other examples of use of ATTREC for line features:

14000002FC5310DE19951126NUM27\0%

This indicates {ATT_ID} 2, feature code 5310: Motorway with road number M27.

14000003FC5825DE00000000FMDORSET COAST PATH\0%

This indicates {ATT_ID} 3, feature code 5825: Long-distance footpath named Dorset Coast Path.

Text record example:

Field	Position	Format	Value example	Description
REC_DESC	01:02	A2	14	
ATT_ID	03:08	I6	000001	

First attribute: feature code

Field	Position	Format	Value example	Description
VAL_TYPE	09:10	A2	FC	Feature code
VALUE	11:14	I4	5040	Positioned name

Second attribute: date

Field	Position	Format	Value example	Description
VAL_TYPE	15:16	A2	DE	Date
VALUE	17:24	DATE	YYYYMMDD	Date of last change

Third attribute: independent text

Field	Position	Format	Value example	Description
VAL_TYPE	25:26	A2	TX	Independent text
VALUE	27:38	A12	CUDDER POINT	
DIVIDER	39:39	A1	\	
CONT_MARK	40:40	I1	0	No continuation record
EOR	41:41	A1	%	Record terminator

Record example:

14000001FC5040DE19991118TXCUDDER POINT\0%

.... 1.... 2.... 3.... 4.... 5.... 6.... 7.... 8
12345678901234567890123456789012345678901234567890123456789012345678901234567890
....

Template

Point record [POINTREC] 15

Field	Position	Format	Value example	Description
REC_DESC	01:02	A2	15	
POINT_ID	03:08	I6	000488	Sequential number of Point Record, starting at 000001
GEOM_ID	09:14	I6	004804	Sequential number of [GEOMETRY1] record, starting at 000001
NUM_ATT	15:16	I2	01	
ATT_ID	17:22	I6	004804	Sequential number of [ATTREC] record, starting at 000001
				If the point feature has no associated [ATTREC] then {ATT_ID} is set to 000000
CONT_MARK	23:23	I1	0	No continuation record
EOR	24:24	A1	%	Record terminator

Record example:

15000488004804010048040%

....1.....2.....3.....4.....5.....6.....7.....8
1234567890123456789012345678901234567890123456789012345678901234567890123456789012345678901234567890								
....

Template

Node record [NODEREC] 16

Field	Position	Format	Value example	Description
REC_DESC	01:02	A2	16	
NODE_ID	03:08	I6	002896	Sequential number of Node Record, starting at 000001
GEOM_ID_OF_POINT	09:14	I6	004804	Identity of a [GEOMETRY1] record containing the position of the node
NUM_LINKS	15:18	I4	0004	Number of links that meet at the node, on Ordnance Survey 1:250 000 scale data the maximum is 10

The following fields are the detail pertaining to each link – they are repeated as many times as the value of {NUM_LINKS}. Node records with {NUM_LINKS} greater than 5 require a continuation record starting with 00 {REC_DESC}.

Field	Position	Format	Value example	Description
DIR	19:19	I1	2	1 if the start of a line, 2 if the end of a line
GEOM_ID_OF_LINK	20:25	I6	004921	{GEOM_ID} of linked feature
ORIENT	26:29	R4,1	2260	Bearing, measured clockwise from grid north, of the first or last segment of the linked feature
LEVEL	30:30	I1	1	Relative levels of the links on the ground; always 1 (default) for level features; over information by feature code

At the record end:

Field	Position	Format	Value example	Description
CONT_MARK	*.*	I1	0	No continuation record or
			1	continuation record follows
EOR	*+1.*+1	A1	%	Record terminator

* = variable integer.

Record example:

1600289600480400042004921226012005034320011005035045011005210165010%

....1....2....3....4....5....6....7....8
12345678901234567890123456789012345678901234567890123456789012345678901234567890								
....

Template

Two-dimensional geometry record [GEOMETRY1] 21

GEOMETRY1 associated with [POINTREC] 15 and [TEXTREC]43

Field	Position	Format	Value example	Description
REC_DESC	01:02	A2	21	
GEOM_ID	03:08	I6	002199	Sequential number of [GEOMETRY1] record, starting at 000001
GTYPE	09:09	I1	1	Point feature
NUM_COORD	10:13	I4	0001	Point has 1 coordinate pair
X_COORD	14:20	I7	0039077	X coordinate
Y_COORD	21:27	I7	0011067	Y coordinate
QPLAN	28:28	A1	<S>	Not used
CONT_MARK	29:29	I1	0	No continuation record
EOR	30:30	A1	%	Record terminator

Note: {X_COORD} and {Y_COORD} are given in metres from the National Grid origin.

Record example:

210021991000100390770011067 0%

....1....2....3....4....5....6....7....8
12345678901234567890123456789012345678901234567890123456789012345678901234567890								
....

Template

GEOMETRY1 associated with LINEREC

Field	Position	Format	Value example	Description
REC_DESC	01:02	A2	21	
GEOM_ID	03:08	I6	015671	Sequential number of [GEOMETRY1] record, starting at 000001
GTYPE	09:09	I1	2	Line feature
NUM_COORD	10:13	I4		Number of coordinates pairs, in the range 0002–9999
X_COORD	14:20	I7		X coordinate
Y_COORD	21:27	I7		Y coordinate
QPLAN	28:28	A1	<S>	Not used
CONT_MARK	*:*	I1	0	No continuation record or
			1	continuation record follows
EOR	*+1:*+1	A1	%	Record terminator

This record may contain many CONTINUATION 00 records.

* = variable integer.

NOTES:

- {X_COORD} and {Y_COORD} are given in metres from the origin of the National Grid.
- {|X_COORD}, {Y_COORD} and {QPLAN} are repeated until {NUM_COORD} has been transferred.

Record example:

```
210156712001500375900009990 00376400009940 00376800009840 00376400009740 1%
0000376000009650 00376100009570 00376000009520 00375100009530 00374500009510 1%
0000373600009510 00373000009560 00373300009670 00374700009840 00375100009950 1%
0000375900009990 0%
```

....	1....	2....	3....	4....	5....	6....	7....	8
1234567890		1234567890		1234567890		1234567890		1234567890		1234567890		1234567890		1234567890		1234567890
....	

Template

Line record [LINEREC] 23

Field	Position	Format	Value example	Description
REC_DESC	01:02	A2	23	
LINE_ID	03:08	I6	004804	Sequential number of [LINEREC] record, starting at 000001
GEOM_ID	09:14	I6	005369	Sequential number identifier of attached [GEOMETRY1] record, starting at 000001
NUM_ATT	15:16	I2	01	
ATT_ID	17:22	I6	005369	Sequential number of attached [ATTREC] record, starting at 000001. If the line feature has no associated [ATTREC] then {ATT_ID} is set to 000000.
CONT_MARK	23:23	I1	0	No continuation record
EOR	24:24	A1	%	Record terminator

Record example:

23004804005369010053690%

.... 1.... 2.... 3.... 4.... 5.... 6.... 7.... 8
123456789012345678901234567890123456789012345678901234567890123456789012345678901234567890
....

Template

Attribute description record [ATTDESC] 40

Field	Position	Format	Value example	Description
REC_DESC	01:02	A2	40	
VAL_TYPE	03:04	A2		See table below
FWIDTH	05:07	A3		See table below
FINTER	08:12	A5		See table below
ATT_NAME	13:*	A*		See table below
DIVIDER	*.*	A1	\	
FDESC	*.*	A*		See table below
DIVIDER	*.*	A1	\	
CONT_MARK	*.*	I1	0	No continuation record
EOR	*.*	A1	%	Record terminator

* = variable integer

Record example:

40NU A* NUMBERED FEATURE\ROAD & ROAD JUNCTION NUMBERS\0%

.... 1.... 2.... 3.... 4.... 5.... 6.... 7.... 8
123456789012345678901234567890123456789012345678901234567890123456789012345678901234567890
....

Template

Valid contents of ATTDESC for Strategi

40DE008I8 DATE\DATE\0%
 40LO001I1 LOCATION\LOCATION\0%
 40UE001I1 USAGE\USAGE\0%
 40HI004I4 HEIGHT_IMPERIAL\HEIGHT IMPERIAL\0%
 40HM004I4 HEIGHT_METRIC\HEIGHT METRIC\0%
 40OR004R4,1 ORIENTATION\ORIENTATION\0%
 40FC004A4 FEATURE_CODE\NUMERIC FEATURE_CODE\0%
 40NU A* NUMBERED FEATURE\ROAD & ROAD JUNCTION NUMBERS\0%
 40RB001A1 BOUNDED REPRESENTATION POINT\POINT SEEDING BOUNDED FEATURES\0%
 40RU001A1 UNBOUNDED REPRESENTATION POINT\POINT SEEDING UNBOUNDED FEATURES\0%
 40TX A* TEXT\INDEPENDENT TEXT\0%
 40GS A* GIS\GIS\0%
 40FM A* FEAT_NAM\FEATURE NAME\0%
 40OW A* OWNER\OWNER\0%
 40CM A* COUNTY_NAME\COUNTY NAME\0%
 40UN A* UNITARY_NAME\UNITARY AUTHORITY NAME\0%
 40DN A* DISTRICT_NAME\DISTRICT NAME\0%
 40RJ A* RESTRICT_NORTH\RESTRICTIONS NORTH\0%
 40RM A* RESTRICT_EAST\RESTRICTIONS EAST\0%
 40RL A* RESTRICT_SOUTH\RESTRICTIONS SOUTH\0%
 40RQ A* RESTRICT_WEST\RESTRICTIONS WEST\0%
 40RW A* RESTRICT_CLOCK\RESTRICTIONS CLOCK\0%
 40RZ A* RESTRICT_ANTICLOCK\RESTRICTIONS ANTICLOCK\0%
 40FE A* FERRY_ACCESS\FERRY ACCESS\0%
 40FR A* FERRY_RESTRICT\FERRY RESTRICTIONS\0%
 40FP A* FERRY_TYPE\FERRY TYPE\0%
 40FF A* FERRY_FROM\FERRY FROM\0%
 40FT A* FERRY_TO\FERRY TO\0%
 40FI A* FERRY_TIME\FERRY TIME\0%

Text record [TEXTREC] 43

Field	Position	Format	Value example	Description
REC_DESC	01:02	A2	43	
TEXT_ID	03:08	I6	000003	Sequential number of [TEXTREC] starting at 000001
NUM_SEL	09:10	I2	01	
SELECT	11:12	A2	00	
TEXT_CODE	13:16	A4	0000	
TEXP_ID	17:22	I6	000003	Sequential number of [TEXTPOS] starting at 000001
NUM_ATT	23:24	I2	01	
ATT_ID	25:30	I6	000267	Next sequential number of [ATTREC]
CONT_MARK	31:31	I1	0	No continuation record
EOR	32:32	A1	%	Record terminator

Record example:

43000003010000000000003010002670%

....1....2....3....4....5....6....7....8
123456789012345678901234567890123456789012345678901234567890123456789012345678901234567890								
....

Template

Text position record [TEXTPOS] 44

Field	Position	Format	Value example	Description
REC_DESC	01:02	A2	44	
TEXP_ID	03:08	I6	000003	Cross reference from [TEXTREC]
NUM_TEXR	09:10	I2	01	
TEXR_ID	11:16	I6	000003	Sequential number of [TEXTREP] starting at 000001
GEOM_ID	17:22	I6	000267	Field contains the {GEOM_ID} of the [GEOMETRY1] record that contains the coordinates of the digitised position of the name
CONT_MARK	23:23	I1	0	No continuation record
EOR	24:24	A1	%	Record terminator

Record example:

44000003010000030002670%

....1....2....3....4....5....6....7....8
1234567890	1234567890	1234567890	1234567890	1234567890	1234567890	1234567890	1234567890	1234567890
....

Template

Text representation record [TEXTREP] 45

Field	Position	Format	Value example	Description
REC_DESC	01:02	A2	45	
TEXR_ID	03:08	I6	000003	Cross reference from [TEXTPOS]
FONT	09:12	I4	0004	0001–0009
TEXT_HT	13:15	R3,1	010	Height in millimetres 010–085
DIG_POSTN	16:16	I1	3	Standard Ordnance Survey digitising position 0–8
ORIENT	17:20	R4,1	0000	Measured anticlockwise from grid east in the range 0000–3599
CONT_MARK	21:21	I1	0	No continuation record
EOR	22:22	A1	%	Record terminator

Record example:

450000030004010300000%

....1....2....3....4....5....6....7....8
1234567890	1234567890	1234567890	1234567890	1234567890	1234567890	1234567890	1234567890	1234567890
....

Template

Volume terminator record [VOLTERM] 99

Field	Position	Format	Value example	Description
_DESC	01:02	A2	99	
FREE_TEXT	03:*	A*		See note below
CONT_VOL	*+1:#+1	I1	0	No continuation volume or
			1	continuation volume follows
EOR	*+2:#+2	A1	%	Record terminator

Notes:

- If there are further volume(s) to follow then the *FREE_TEXT* field comprises the following message
'End Of Volume (nn). Transfer Set Continues On Volume (nn+1).
- If there are no further volumes then the *FREE_TEXT* field will READ:
End Of Transfer Set

* = variable integer

Record examples:

99End Of Volume 01 Transfer Set Continues On Volume 021%

....1....2....3....4....5....6....7....8
12345678901234567890123456789012345678901234567890123456789012345678901234567890
....

Template

99End Of Transfer Set0%

....1....2....3....4....5....6....7....8
12345678901234567890123456789012345678901234567890123456789012345678901234567890
....

Template

Chapter 4 DXF explained

Introduction

The purpose of this chapter and [chapter 5](#) is to:

- Provide a brief description of the presentation of Strategi in the DXF transfer format.
 - Data Exchange Format (DXF) (conforming to AutoCAD release 12 with extended entity data).

As part of this description, data structure diagrams are used to give greater explanation where necessary.

The term data structure used in these chapters refers to the organisation and sequence of the records in the data file and not to the geographical topology of the data.

These chapters should be read in conjunction with chapters 1, 2 and 3, which describe the content of Strategi.

An overview of Strategi in DXF

Data Exchange Format (DXF)

Strategi is available in DXF, conforming to AutoCAD release 12 using extended entity data to store attributes. The transfer format is that defined by the NEDO Working Party for the exchange of two-dimensional drawings in the construction industry. An overview of the data structure of a Strategi file in DXF is shown below:

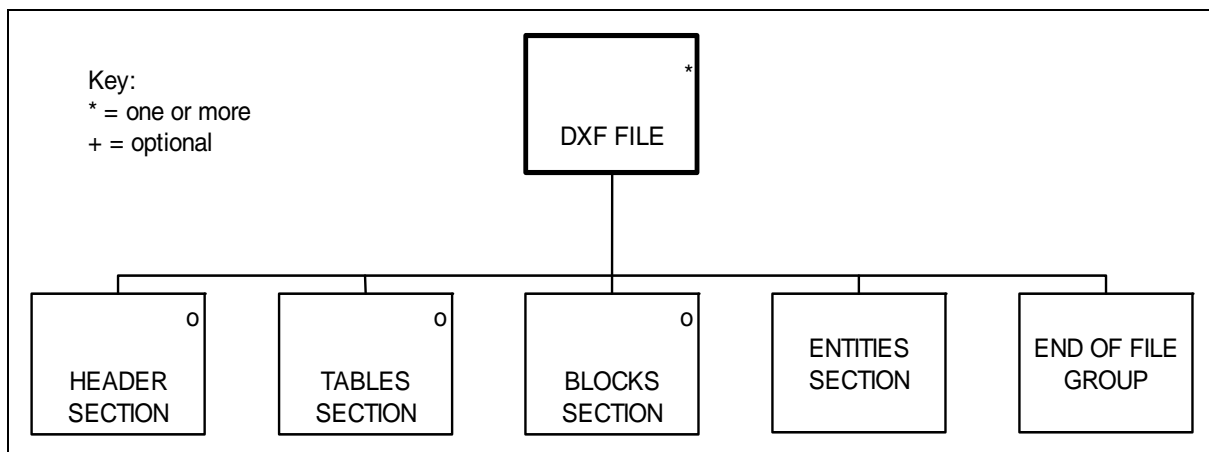

Structure of Strategi in DXF

Strategi has a limited *link-and-node* data structure; within this structure a feature may be a name, a point or a line (or series of lines forming a coherent unit). Each feature is free-standing; that is, its topological relationship to any other feature is **not** expressed in the data.

Feature representation

Features are classified by type and each type is placed in a separate DXF layer.

Line features

A feature is a subjective entity; that is, as long as the constituent lines are of the same description (layer), a feature need not fully describe a logical piece of detail.

The extent of a feature is determined by digitising conventions and does not always coincide with the topology. Each linear feature is composed of a string of XY coordinate pairs implicitly joined by straight lines.

The colour and line weights of some layers may differ when DXF is used with certain software packages.

Area features

Area features are not defined within vector link-and-node data. Features that might be thought of as *areas* are treated in the data as linear features, for example, a woodland outline is treated as a polyline in layer G8065610.

Name features

Name features are treated as free-standing text data. There is no explicit relationship (in the data) between a text feature and the point or line feature to which it belongs.

Ordnance Survey distinguishes between layer name types – for example, motorway numbers and water names – by placing each name type in a separate DXF layer.

Text has position, expressed as a single coordinate pair, held as X and Y National Grid coordinates. Text that is double- or treble-banked is treated as two or three separate features. The text string may be considered to be contained within an *envelope* whose bottom left corner is positioned on this coordinate pair. Text is oriented, that is, it may run from west to east across the map, or it may be plotted at some other angle measured anticlockwise from grid east.

Information specific to DXF

Coordinate system

The coordinate system is the National Grid. The coordinates are to a resolution of 1 m. This is the resolution of the source data.

Height

No height attributes are applied to any feature.

Layer names

Layer Naming Convention for CAD in the Construction Industry Version 2, which is based upon the guidelines laid down in BS 1192: Part 5 – *Guide for structuring of computer graphic information* has been adopted.

Each layer name is an eight-character string. The first four characters relate to the AUG/Autodesk® system, with G (GIS) as the source of the information, and 800–899 as the part code. This product is **G806**. The remaining four digits relate to existing Ordnance Survey digital map data in their own NTF system and are leading zero-filled.

For example: G8065310 – Motorway.

Neatline

A *Neatline* around the extent of the map data is added as lines in the ENTITIES section, (Layer name G8060572).

Grid

A grid is added as lines in the ENTITIES section (Grid lines and values layer name G8060572). The grid is created by the translator and therefore must be specified before the translation takes place.

Copyright

© Crown copyright is inserted at the origin of the data (0,0).

Strategi DXF layers

Feature code	Feature name	Linetype	Line	Entity	Colour	Block
G8060571	Footnotes	STANDARD		TEXT	WHITE	ST_FOOTNO
G8060572	Grid lines and values	CONTINUOUS	1	INSERT/TEXT	WHITE	
G8060573	Grid values	STANDARD	1		WHITE	
G8060575	Default	CONTINUOUS	1	POLYLINE	WHITE	
G8065006	Non-primary route destination town graphic text	STANDARD		TEXT	WHITE	
G8065016	Other graphic text	STANDARD		TEXT	WHITE	
G8065020	Water feature graphic text	STANDARD		TEXT	CYAN	
G8065025	Primary route destination city graphic text	STANDARD		TEXT	GREEN	
G8065026	Non-primary route destination city graphic text	STANDARD		TEXT	WHITE	
G8065031	Motorway number graphic text	STANDARD		TEXT	BLUE	
G8065032	Primary route number graphic text	STANDARD		TEXT	GREEN	
G8065033	A road number graphic text	STANDARD		TEXT	RED	
G8065034	B road number graphic text	STANDARD		TEXT	ORANGE	
G8065036	Road distance mileage (motorway) graphic text	STANDARD		TEXT	WHITE	
G8065037	Road distance (primary and A) graphic text	STANDARD		TEXT	WHITE	
G8065038	Toll graphic text	STANDARD		TEXT	WHITE	
G8065039	Ferry annotation graphic text	STANDARD		TEXT	ORANGE	
G8065040	Non-primary route village graphic text	STANDARD		TEXT	WHITE	
G8065041	Primary route destination town graphic text	STANDARD		TEXT	GREEN	
G8065042	Motorway junction number (full access) graphic text	STANDARD		TEXT	BLUE	
G8065043	Motorway junction number (limited access) graphic text	STANDARD		TEXT	WHITE	
G8065044	Tourist feature graphic text	STANDARD		TEXT	WHITE	
G8065045	National trail, long distance path and route graphic text	STANDARD		TEXT	GREEN	
G8065046	National park/forest park graphic text	STANDARD		TEXT	GREEN	
G8065048	Services text	STANDARD		TEXT	BLUE	
G8065049	Primary route destination village graphic text	STANDARD		TEXT	GREEN	
G8065060	Geographic area graphic text	STANDARD		TEXT	WHITE	
G8065061	Large hills, ranges and summits graphic text	STANDARD		TEXT	WHITE	
G8065062	Named hills, islands and rocks graphic text	STANDARD		TEXT	WHITE	
G8065081	Roman antiquity graphic text (AD 43–AD 420)	STANDARD		TEXT	WHITE	
G8065082	Non-Roman antiquities graphic text	STANDARD		TEXT	WHITE	
G8065090	Spot height value graphic text	STANDARD		TEXT	WHITE	
G8065107	Road distance marker (primary & A)	CONTINUOUS		INSERT	GREEN	R_MARK
G8065108	Road distance marker (Motorway)	CONTINUOUS		INSERT	BLUE	M_MARK
G8065109	Dual junction graphic text divider line	CONTINUOUS		INSERT	WHITE	DUTXDIVL
G8065110	Coastline and offshore rocks above mean high water	CONTINUOUS	3	POLYLINE	BLUE	
G8065115	Sea seed below mean high water	CONTINUOUS		INSERT	BLUE	SEEDPOINT
G8065120	Foreshore (sand, outer limit)	CONTINUOUS	1	POLYLINE	YELLOW	
G8065121	Foreshore (sand) seed	CONTINUOUS		INSERT	YELLOW	SEEDPOINT
G8065122	Foreshore (other) and offshore rocks exposed at mean low water, outer limit)	CONTINUOUS	1	POLYLINE	CYAN	
G8065123	Foreshore (other) and offshore rocks exposed at mean low water seed	CONTINUOUS		INSERT	CYAN	SEEDPOINT
G8065140	Lighthouse (in use)	CONTINUOUS		INSERT	BLUE	LHINUSE
G8065141	Lightship	CONTINUOUS		INSERT	BLUE	LIGHTSHIP

Feature code	Feature name	Linetype	Line	Entity	Colour	Block
G8065142	Lighthouse (disused)	CONTINUOUS		INSERT	BLUE	LHDISUSE
G8065200	Unspecified node	CONTINUOUS		INSERT	MAGENTA	CIRCLE (small)
G8065211	River (primary), source	CONTINUOUS	1	POLYLINE	CYAN	
G8065212	River (primary), middle	CONTINUOUS	1	POLYLINE	CYAN	
G8065213	River (primary), lower	CONTINUOUS	1	POLYLINE	CYAN	
G8065221	River (secondary), source	CONTINUOUS	1	POLYLINE	CYAN	
G8065222	River (secondary), middle	CONTINUOUS	1	POLYLINE	CYAN	
G8065230	River (other and drains)	CONTINUOUS	1	POLYLINE	CYAN	
G8065240	Canal	CONTINUOUS	1	POLYLINE	CYAN	
G8065241	Canal tunnel	DASHED	1	POLYLINE	CYAN	
G8065242	Canal (over)	CONTINUOUS	1	POLYLINE	CYAN	
G8065250	Inland water (outer limit)	CONTINUOUS	1	POLYLINE	CYAN	
G8065251	Inland water seed	CONTINUOUS		INSERT	CYAN	SEEDPOINT
G8065300	Motorway (under construction)	DASHED		POLYLINE	BLUE	
G8065301	Motorway (under construction, over)	DASHED		POLYLINE	BLUE	
G8065302	Primary route, dual carriageway (under construction)	DASHED		POLYLINE	GREEN	
G8065303	Primary route, dual carriageway (under construction, over)	DASHED		POLYLINE	GREEN	
G8065304	Primary route, single carriageway (under construction)	DASHED		POLYLINE	GREEN	
G8065305	Primary route, single carriageway (under construction, over)	DASHED		POLYLINE	GREEN	
G8065306	A road, dual carriageway (under construction)	DASHED		POLYLINE	RED	
G8065307	A road, dual carriageway (under construction, over)	DASHED		POLYLINE	RED	
G8065308	A road, single carriageway (under construction)	DASHED		POLYLINE	RED	
G8065309	A road, single carriageway (under construction, over)	DASHED		POLYLINE	RED	
G8065310	Motorway	CONTINUOUS	3	POLYLINE	BLUE	
G8065311	Motorway, planned	DASHED	3	POLYLINE	BLUE	
G8065312	Motorway (over)	CONTINUOUS	3	POLYLINE	BLUE	
G8065313	Motorway tunnel	DASHED	1	POLYLINE	WHITE	
G8065314	Road tunnel (end symbol)	CONTINUOUS		INSERT	WHITE	
G8065320	Primary route, dual carriageway	CONTINUOUS	2	POLYLINE	GREEN	
G8065321	Primary route, dual carriageway planned	DASHED	2	POLYLINE	GREEN	
G8065322	Primary route, dual carriageway (over)	CONTINUOUS	2	POLYLINE	GREEN	
G8065323	Primary route, single carriageway	CONTINUOUS	1	POLYLINE	GREEN	
G8065324	Primary route, single carriageway planned	DASHED	1	POLYLINE	GREEN	
G8065325	Primary route, single carriageway (over)	CONTINUOUS	1	POLYLINE	GREEN	
G8065326	Primary route, narrow	CONTINUOUS	1	POLYLINE	GREEN	
G8065327	Primary route, narrow (over)	CONTINUOUS	1	POLYLINE	GREEN	
G8065330	A road, dual carriageway	CONTINUOUS	2	POLYLINE	RED	
G8065331	A road, dual carriageway planned	DASHED	2	POLYLINE	RED	
G8065332	A road, dual carriageway (over)	CONTINUOUS	2	POLYLINE	RED	
G8065333	A road, single carriageway	CONTINUOUS	1	POLYLINE	RED	
G8065334	A road, single carriageway planned	DASHED	1	POLYLINE	RED	
G8065335	A road, single carriageway (over)	CONTINUOUS	1	POLYLINE	RED	
G8065336	A road, narrow	CONTINUOUS	1	POLYLINE	RED	
G8065337	A road, narrow (over)	CONTINUOUS	1	POLYLINE	RED	
G8065340	B road, dual carriageway	CONTINUOUS	2	POLYLINE	ORANGE	
G8065342	B road, dual carriageway (over)	CONTINUOUS	2	POLYLINE	ORANGE	
G8065343	B road, single carriageway	CONTINUOUS	1	POLYLINE	ORANGE	
G8065345	B road, single carriageway (over)	CONTINUOUS	1	POLYLINE	ORANGE	

Feature code	Feature name	Linetype	Line	Entity	Colour	Block
G8065346	B road, narrow	CONTINUOUS	1	POLYLINE	ORANGE	
G8065347	B road, narrow (over)	CONTINUOUS	1	POLYLINE	ORANGE	
G8065350	Minor road over 4 metres wide	CONTINUOUS	1	POLYLINE	WHITE	
G8065351	Minor road over 4 metres wide (over)	CONTINUOUS	1	POLYLINE	WHITE	
G8065353	Minor road over 4 metres wide tunnel	DASHED		POLYLINE	WHITE	
G8065355	Roundabout (primary route, dual carriageway)	CONTINUOUS		INSERT	GREEN	RBOUT
G8065356	Roundabout (A road, dual carriageway)	CONTINUOUS		INSERT	RED	RBOUT
G8065357	Roundabout (B road, dual carriageway)	CONTINUOUS		INSERT	ORANGE	RBOUT
G8065358	A road tunnel	DASHED		POLYLINE	RED	
G8065359	B road tunnel	DASHED		POLYLINE	ORANGE	
G8065360	Service station (full access)	CONTINUOUS		INSERT	BLUE	SERVICES
G8065361	Service station (limited access)	CONTINUOUS		INSERT	BLUE	SERV_LTD
G8065370	Motorway junction (full access)	CONTINUOUS		INSERT	BLUE	JUNCTION
G8065371	Motorway junction (limited access)	CONTINUOUS		INSERT	BLUE	JUNCTION
G8065372	Motorway junction (under construction)	CONTINUOUS		INSERT	WHITE	JUNCTION
G8065373	Primary route tunnel	DASHED		POLYLINE	GREEN	
G8065374	Roundabout (minor road over 4 m wide)	CONTINUOUS		INSERT	WHITE	RBOUT
G8065375	Roundabout (primary route, single carriageway)	CONTINUOUS		INSERT	GREEN	RBOUT
G8065376	Roundabout (A road, single carriageway)	CONTINUOUS		INSERT	RED	RBOUT
G8065377	Roundabout (B road, single carriageway)	CONTINUOUS		INSERT	ORANGE	RBOUT
G8065378	Multilevel junction (under construction)	CONTINUOUS		INSERT	GREY	MULT_JUNC
G8065379	Multilevel junction (full access)	CONTINUOUS		INSERT	WHITE	MULT_JUNC
G8065380	Gradient 1 in 7 (14%) or steeper on primary, A and B roads	CONTINUOUS		INSERT	WHITE	GRADIENT
G8065381	Roundabout (under construction)	CONTINUOUS		INSERT	BLUE	RBOUT_UNC
G8065382	Toll bar	CONTINUOUS		INSERT	WHITE	TOLL
G8065384	Other track or road	CONTINUOUS		POLYLINE	WHITE	
G8065385	Other track or road (over)	CONTINUOUS		POLYLINE	WHITE	
G8065389	Multilevel junction (limited access)	CONTINUOUS		INSERT	WHITE	MULT_LA
G8065390	Vehicular ferry route	DASHED	1	POLYLINE	WHITE	
G8065392	Service station (non-24 hour)	CONTINUOUS		INSERT	WHITE	SERV_N24
G8065393	Ferry route link	DASHED	1	POLYLINE	WHITE	
G8065397	100 km accentuated grid line	CONTINUOUS		POLYLINE	BLACK	
G8065398	10 km grid line	CONTINUOUS		POLYLINE	BLACK	
G8065403	Dead-end road generally under 4 m wide	CONTINUOUS		POLYLINE	WHITE	
G8065404	Dead-end road generally under 4 metres wide (over)	CONTINUOUS		POLYLINE	WHITE	
G8065405	Minor road under 4 metres wide	CONTINUOUS		POLYLINE	WHITE	
G8065406	Minor road under 4 metres wide (over)	CONTINUOUS		POLYLINE	WHITE	
G8065407	Minor road under 4 metres wide tunnel	DASHED		POLYLINE	WHITE	
G8065408	Roundabout (minor road under 4 metres wide)	DASHED		INSERT	WHITE	RBOUT
G8065413	Town attribute point	CONTINUOUS		INSERT	GREEN	SEEDPOINT
G8065416	Village attribute point	CONTINUOUS		INSERT	WHITE	SEEDPOINT
G8065419	Landmark attribute point	CONTINUOUS		INSERT	WHITE	SEEDPOINT
G8065420	Large urban area (outer limit)	CONTINUOUS	3	POLYLINE	GREY	
G8065421	Large urban area seed	CONTINUOUS		INSERT	GREY	DLUASEED
G8065422	Small urban area (outer limit)	CONTINUOUS	3	POLYLINE	GREY	
G8065423	Small urban area seed	CONTINUOUS		INSERT	GREY	DLUASEED
G8065427	City attribute point	CONTINUOUS		INSERT	WHITE	SEEDPOINT
G8065490	Inland water (inner limit)	CONTINUOUS		POLYLINE	CYAN	
G8065491	Wood/forest (inner limit)	DASH-DOT	1	POLYLINE	GREEN	
G8065492	Large urban area (inner limit)	CONTINUOUS	3	POLYLINE	GREY	

Feature code	Feature name	Linetype	Line	Entity	Colour	Block
G8065493	Small urban area (inner limit)	CONTINUOUS	3	POLYLINE	GREY	
G8065494	Foreshore (sand, inner limit)	CONTINUOUS	1	POLYLINE	YELLOW	
G8065495	Foreshore (other) and offshore rocks exposed at mean low water, inner limit	CONTINUOUS	1	POLYLINE	CYAN	
G8065510	Railway, standard gauge	CONTINUOUS	3	POLYLINE	WHITE	
G8065511	Railway, standard gauge (over)	CONTINUOUS	3	POLYLINE	WHITE	
G8065512	Railway, narrow gauge	CONTINUOUS	1	POLYLINE	WHITE	
G8065513	Railway, narrow gauge (over)	CONTINUOUS	1	POLYLINE	WHITE	
G8065514	Railway tunnel	DASHED	1	POLYLINE	WHITE	
G8065519	Railway line under construction	CONTINUOUS		POLYLINE	WHITE	
G8065520	Railway station	CONTINUOUS		POINT	WHITE/RED	STATION
G8065521	Rapid transit station	CONTINUOUS		POINT	WHITE	
G8065522	Rapid transit line	CONTINUOUS		POLYLINE	WHITE	
G8065523	Rapid transit line (over)	CONTINUOUS		POLYLINE	WHITE	
G8065524	Rapid transit tunnel	DASHED		POLYLINE	WHITE	
G8065525	Rapid transit line (U/C)	CONTINUOUS		POLYLINE	WHITE	
G8065530	Level crossing on classified road	CONTINUOUS		INSERT	WHITE	LEVCROSS
G8065531	Level crossing on unclassified road	CONTINUOUS		INSERT	WHITE	LEVCROSS
G8065610	Wood/forest (outer limit)	DASH-DOT	1	POLYLINE	GREEN	
G8065611	Wood/forest seed	CONTINUOUS		INSERT	GREEN	WOODSEED
G8065612	Marsh	CONTINUOUS		INSERT	GREEN	MARSH
G8065620	Geographic area attribute point	CONTINUOUS		INSERT	WHITE	SEEDPOINT
G8065621	Island area attribute point	CONTINUOUS		INSERT	WHITE	SEEDPOINT
G8065710	National boundary	DASH-DOT	1	POLYLINE	WHITE	
G8065715	National primary attribute point	CONTINUOUS		INSERT	WHITE	SEEDPOINT
G8065720	County boundary	DASHED	1	POLYLINE	WHITE	
G8065721	County name graphic text	STANDARD		TEXT	WHITE	
G8065725	County primary attribute point	CONTINUOUS		INSERT	WHITE	SEEDPOINT
G8065730	District boundary	DASHED		POLYLINE	WHITE	
G8065731	District name graphic text	STANDARD		TEXT	WHITE	
G8065733	District primary attribute point	CONTINUOUS		INSERT	WHITE	DIS_AP
G8065734	Administrative detached attribute point	CONTINUOUS		INSERT	WHITE	ADM_AP
G8065740	Unitary authority boundary	DASHED		POLYLINE	WHITE	
G8065741	Unitary authority name graphic text	STANDARD		TEXT	WHITE	
G8065744	Unitary authority primary attribute point	CONTINUOUS		INSERT	WHITE	UNI_AP
G8065750	Associated area boundary	DASHED		POLYLINE	WHITE	
G8065805	Camping and caravanning combined site	CONTINUOUS		INSERT	WHITE	CAMPCAR
G8065806	Park and ride	CONTINUOUS		INSERT	WHITE	PANDR
G8065810	Roman road	CONTINUOUS	1	POLYLINE	WHITE	
G8065812	Antiquity line detail (dyke, wall and so on)	CONTINUOUS	1	POLYLINE	WHITE	
G8065815	Hill fort	CONTINUOUS		INSERT	WHITE	HILLFORT
G8065816	Battlefield	CONTINUOUS		INSERT	WHITE	BATTLE
G8065820	National park/forest park	CONTINUOUS	1	POLYLINE	YELLOW	
G8065821	National park/forest park attribute point	CONTINUOUS		INSERT	YELLOW	SEEDPOINT
G8065825	National trail, long distance path and route	DASHED	1	POLYLINE	GREEN	
G8065835	Television, radio mast or tower	CONTINUOUS		INSERT	WHITE	MAST
G8065837	Telephone dot	CONTINUOUS		INSERT	WHITE	PHONEDOT
G8065838	Landmark/antiquity dot	CONTINUOUS		INSERT	WHITE	LANDOT
G8065839	Airport with customs (no scheduled flights)	CONTINUOUS		INSERT	WHITE	AIRCUST
G8065840	Airport without customs facilities	CONTINUOUS		INSERT	RED	AIRNOCUST
G8065841	Airport with permanent customs facilities where no prior notification is necessary	CONTINUOUS		INSERT	GREEN	AIRCUST
G8065843	Wind-powered generator	CONTINUOUS		INSERT	WHITE	WINDGEN
G8065844	Windmill	CONTINUOUS		INSERT	WHITE	WINDMILL
G8065845	Heliport	CONTINUOUS		INSERT	WHITE	HELIPORT

Feature code	Feature name	Linetype	Line	Entity	Colour	Block
G8065847	Public telephone	CONTINUOUS		INSERT	WHITE	PUBTEL
G8065849	Motoring organisation telephone	CONTINUOUS		INSERT	WHITE	MOTTEL
G8065851	Theme park (open to the public)	CONTINUOUS		INSERT	WHITE	THEMEPK
G8065860	Abbey, cathedral, priory (open to the public)	CONTINUOUS		INSERT	WHITE	ABBEY
G8065861	Camp site	CONTINUOUS		INSERT	WHITE	CAMP
G8065862	Caravan site	CONTINUOUS		INSERT	WHITE	CARAVAN
G8065863	Golf course	CONTINUOUS		INSERT	WHITE	GCOURSE
G8065864	Museum (open to the public)	CONTINUOUS		INSERT	WHITE	MUSEUM
G8065865	Picnic site	CONTINUOUS		INSERT	WHITE	PICSITE
G8065866	Tourist information centre (open all year)	CONTINUOUS		INSERT	WHITE	TICA
G8065867	Country park (open to the public)	CONTINUOUS		INSERT	GREEN	CTPARK
G8065868	Youth hostel	CONTINUOUS		INSERT	WHITE	YHOST
G8065869	Nature or forest trail	DASHED		INSERT	GREEN	NTRAIL
G8065870	Zoo (open to the public)	CONTINUOUS		INSERT	WHITE	ZOO
G8065871	Preserved railway	CONTINUOUS		INSERT	WHITE	PRESRLY
G8065873	Craft centre (open to the public)	CONTINUOUS		INSERT	WHITE	CRAFTC
G8065874	Wildlife centre (open to the public)	CONTINUOUS		INSERT	GREEN	WILDC
G8065875	Aquarium (open to the public)	CONTINUOUS		INSERT	CYAN	AQUAM
G8065876	Cave (open to the public)	CONTINUOUS		INSERT	WHITE	CAVE
G8065877	Castle (open to the public)	CONTINUOUS		INSERT	WHITE	CASTLE
G8065878	Historic house (open to the public)	CONTINUOUS		INSERT	WHITE	HISHSE
G8065879	Motor racing circuit	CONTINUOUS		INSERT	WHITE	MRCIRC
G8065880	Nature reserve	CONTINUOUS		INSERT	GREEN	NATRES
G8065881	Viewpoint (limited)	CONTINUOUS		INSERT	WHITE	VIEW
G8065882	Viewpoint (360°)	CONTINUOUS		INSERT	WHITE	VIEW360
G8065883	Other tourist attraction (open to the public)	CONTINUOUS		INSERT	WHITE	OTOURA
G8065884	Ski slope	CONTINUOUS		INSERT	WHITE	SKISL
G8065885	Racecourse	CONTINUOUS		INSERT	WHITE	RACEC
G8065886	Garden (open to the public)	CONTINUOUS		INSERT	GREEN	GARDEN
G8065887	Ferry boat	CONTINUOUS		INSERT	CYAN	FERRY
G8065888	Ferry hovercraft	CONTINUOUS		INSERT	CYAN	HOVER
G8065889	Tourist information centre (seasonal)	CONTINUOUS		INSERT	WHITE	TICS
G8065890	Ferry box outline	CONTINUOUS		POLYLINE	CYAN	
G8065892	Ferry catamaran	CONTINUOUS		INSERT	CYAN	CATAM
G8065901	Spot height dots	CONTINUOUS		INSERT	WHITE	SEEDPOINT

Chapter 5 DXF file structure for Strategi

General

The following paragraphs describe the DXF group and section structure for the transfer of Strategi.

It is assumed that the reader of this chapter is familiar with the AutoCAD reference manual, which is published by:

Autodesk Ltd
1 Meadow Gate Avenue
Farnborough Business Park
FARNBOROUGH
GU14 6FG

or an equivalent document published by the reader's software supplier if a CAD package other than AutoCAD is to be used.

The following section gives a detailed breakdown of the data structure of Strategi in DXF.

This is a two stage procedure that consists of:

- 1 Diagrammatic view of the data structure with a preceding outline description of that part of the data structure.
- 2 Detailed examples of the record sequence and contents of the data structure. A diagram of the record group precedes each example.

Data structure

The following diagrams (figures 5.1–5.17) represent the data structure of DXF. Where one element of a figure is the starting point for another figure; this is indicated beneath the relevant box.

Figure 5.1: Level 1

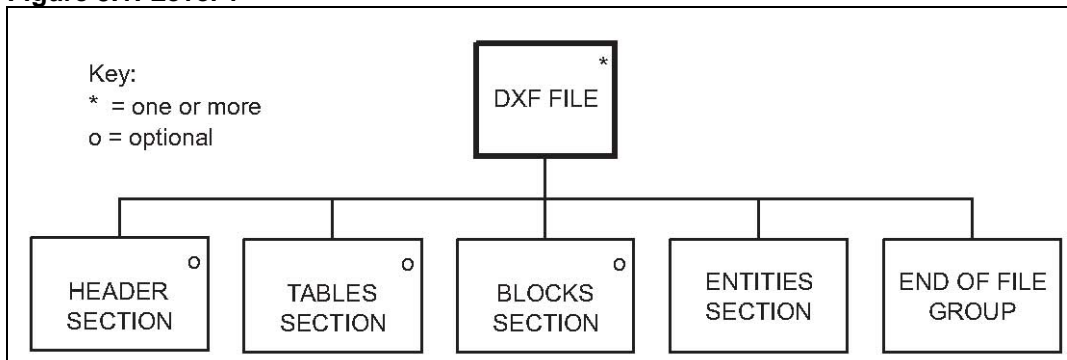

(Figure 5.2)

(Figure 5.3)

(Figure 5.9)

(Figure 5.12)

Header

Figure 5.2: Level 2

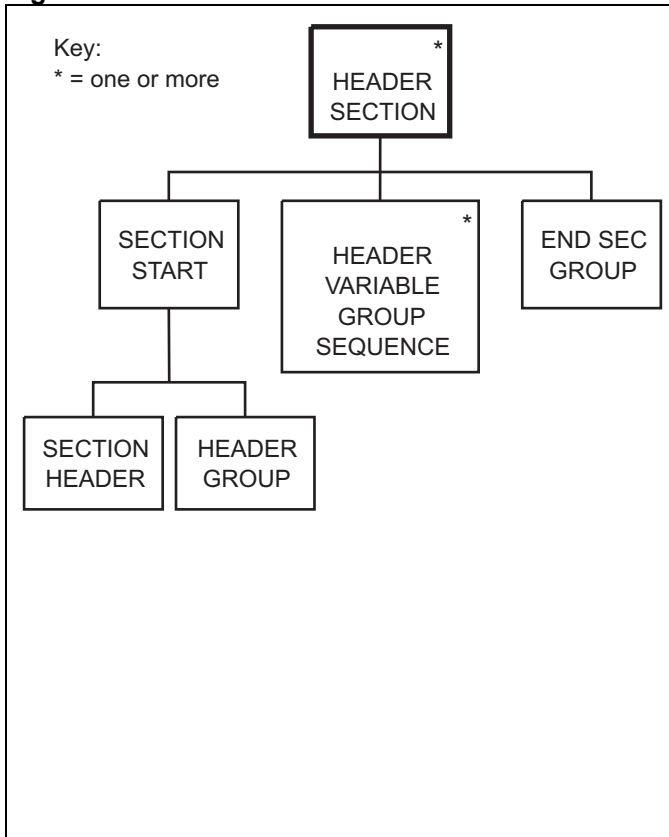

The Header section will begin as:

```

0
SECTION
2
HEADER
9
  
```

\$ACADVER AutoCAD drawing database version number.

1

AC1009 This indicates release 11 or 12 (not 9).

9

The information that follows contains settings of variables associated with the drawing. These are set with various commands and are the type of information displayed by the STATUS command. Each variable is specified in the Header section by a 9-group giving the variable's name, followed by the groups that supply the variable's value. Descriptions of all header information can be found in the AutoCAD reference manual.

The header information will end with the following variable:

0

ENDSEC

End of section.

Tables

Figure 5.3: Level 2

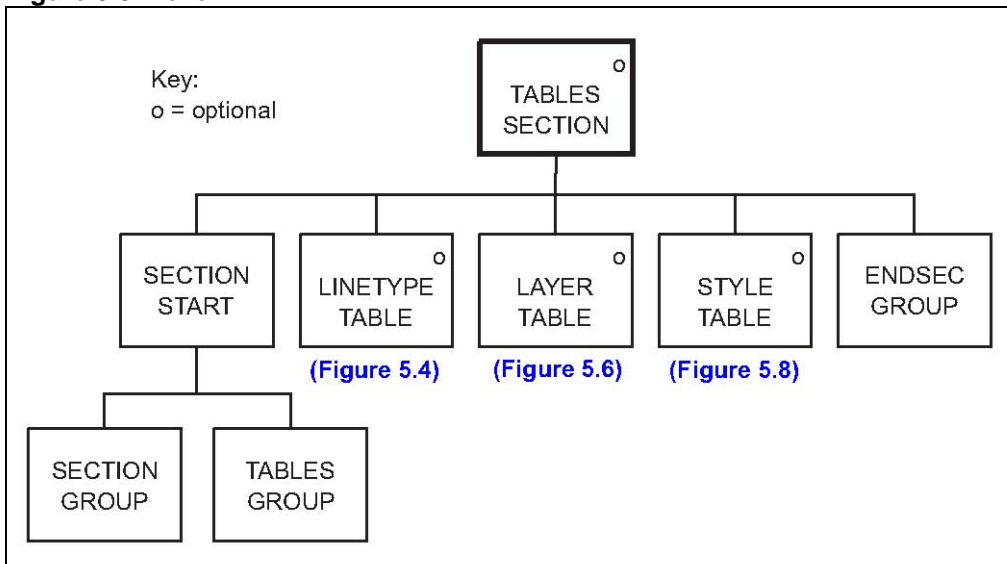

The tables section will follow the header section and will contain three tables:

- Linetype table
- Layer table
- Style table

Figure 5.4: Linetype table level 3

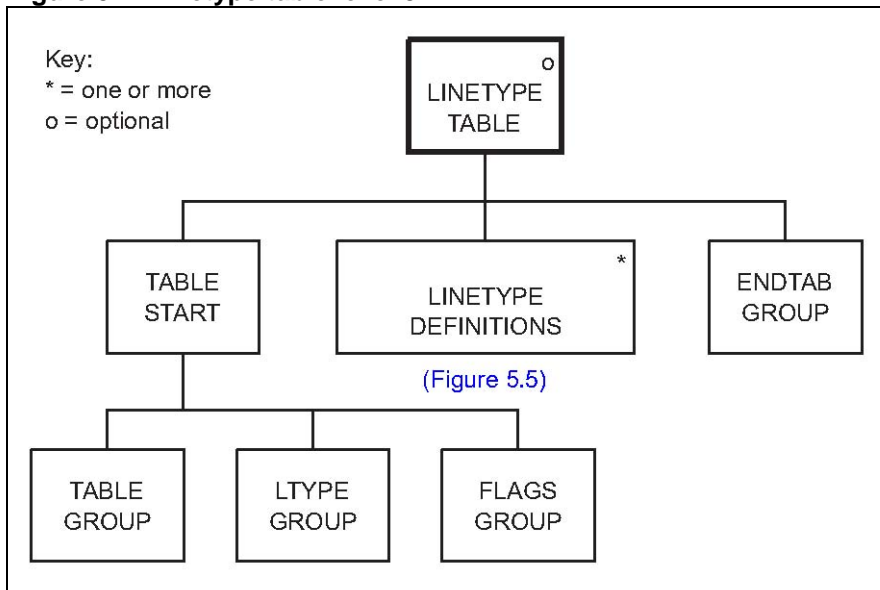

The linetype table will contain definitions for the following line types:

- solid line (CONTINUOUS)
- dashed line (DASHED)
- dash-dot line(DASH-DOT)

Figure 5.5: Level 4

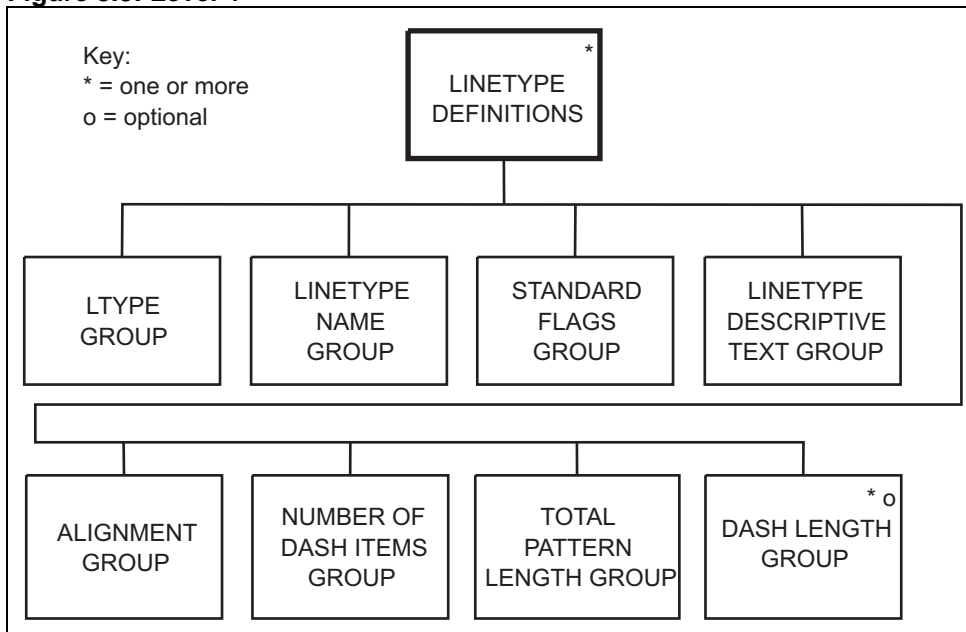

Thus:

0
TABLE
2
LTYPE
70
5

0
LTYPE
2
CONTINUOUS
70
64

3
Solid Line
72
65
73
0

40
0.0
0
LTYPE
2
DASHED
70
64

3

72
65
73
2
40
0.75

49
0.5
49
-0.25
0
LTYPE
2

DASHDOT
70
0
3

72
65
73
4
40
1.0

49
0.5
49
-0.25
49
0.0

49
-0.25
0
ENDTAB

Figure 5.6: Level 3

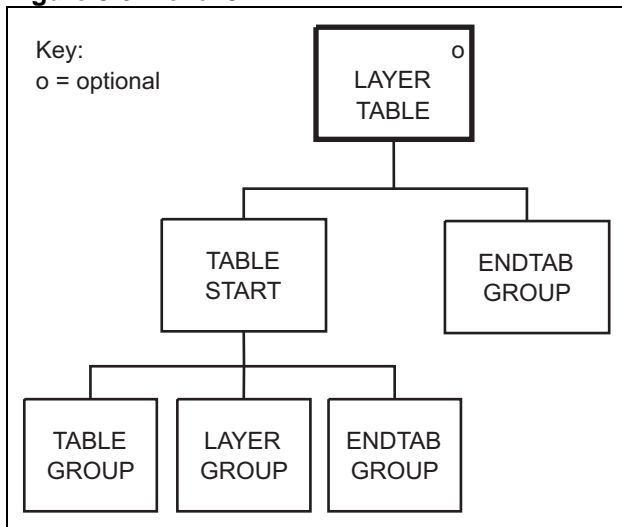

Details of the layer table can be seen in [chapter 4](#).

Figure 5.7: Level 4

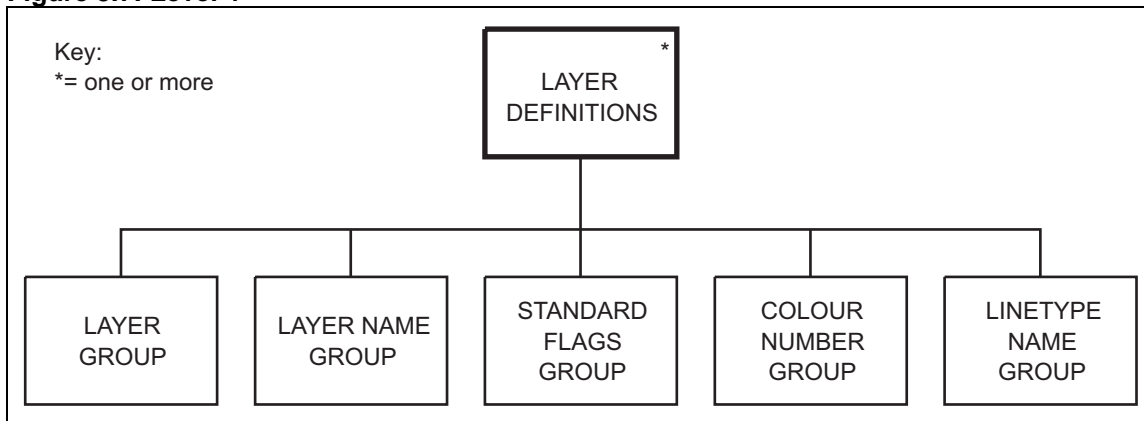
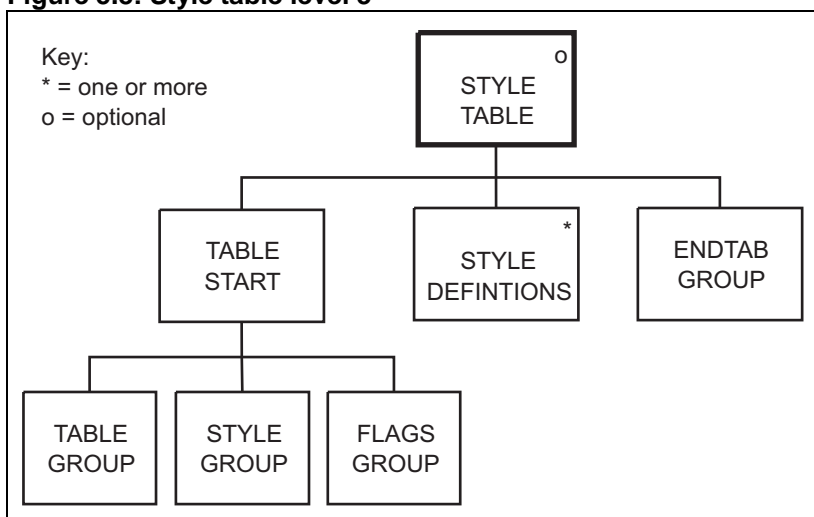

Figure 5.8: Style table level 3



The style table will contain the text file load instructions for:

- SIMPLEX.SHX
- MONOTEXT.SHX

Figure 5.9: Level 4

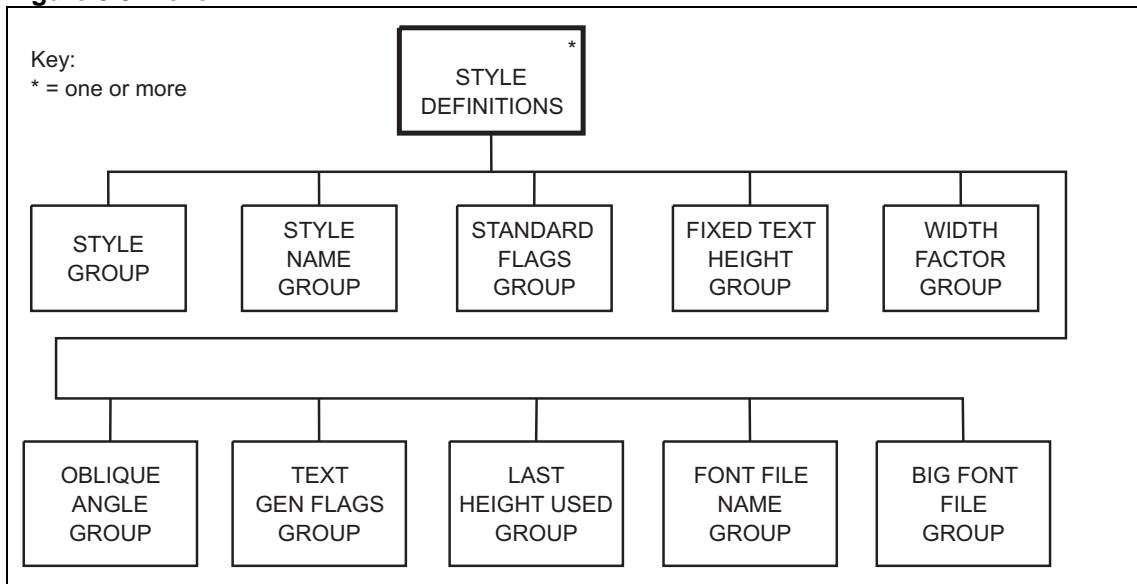

Blocks

Figure 5.10: Level 2

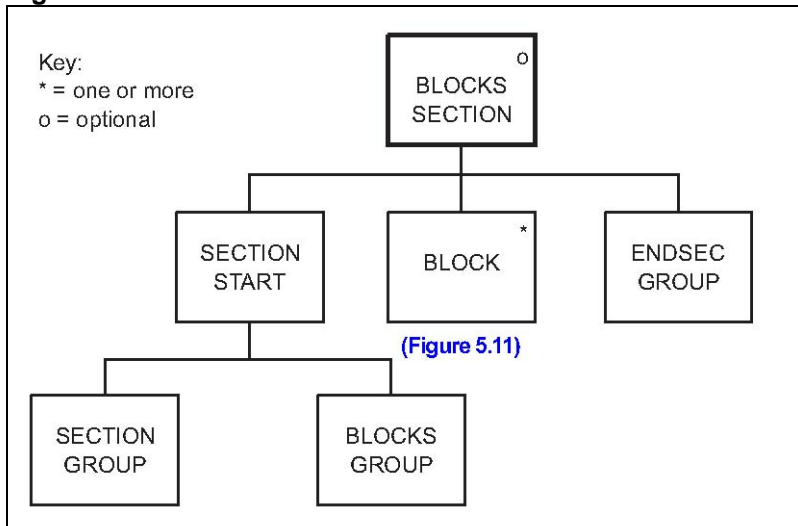
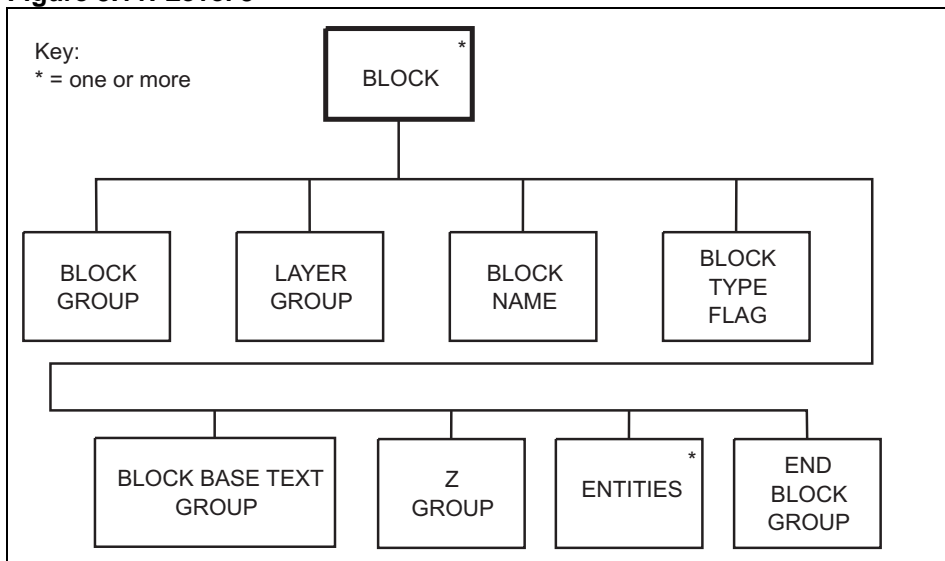

Figure 5.11: Level 3



Entities section

The entities section will contain DXF entities for Ordnance Survey map footnotes data (INSERT entities); grid and neatline (TEXT and LINE entities); Ordnance Survey features (TEXT, POLYLINE and INSERT entities); and extended entity data to store attributes. The structure of each different entity is as follows:

a INSERT entities – these consist of:

- INSERT entity type group (attribute number 0)
- Layer name group (8)
- Block name group (2)
- X coordinate group (10)
- Y coordinate group (20)
- Z coordinate group (30)
- X scale factor (41) optional
- Y scale factor (42) optional
- Z scale factor (43) optional
- Rotation angle (50) optional if 0

b LINE entities – these consist of:

- LINE entity type group (0)
- Layer name group (8)
- Start X coordinate group (10)
- Start Y coordinate group (20)
- Start Z coordinate group (30)
- End X coordinate group (11)
- End Y coordinate group (21)
- End Z coordinate group (31)

c POLYLINE entities – these consist of:

- POLYLINE entity type group (0)
- Layer name group (8)
- Vertices follow flag (66)
- X elevation (10) set to 0
- Y elevation (20) set to 0
- Z elevation (30)
- Default starting width(40) optional if 0
- Default ending width (41) optional if 0
- A number of VERTEX entities shown below
- SEQEND group (0)

d VERTEX entities – these consist of:

- VERTEX entity type group (0)
- Layer name group (8)
- X coordinate group (10)
- Y coordinate group (20)
- Z coordinate group (30)
- Starting width (40) optional
- Ending width (41) optional
- Bulge (42) optional if 0
- Vertex flags (70) optional if 0
- Curve fit tangent (50) optional

e TEXT entities – these consist of:

- TEXT entity type group (0)
- Layer name group (8)
- X coordinate group (10)
- Y coordinate group (20)
- Z coordinate group (30)
- Text height group (40)
- Text value (1)
- Rotation angle group(50) optional if 0
- Relative X scale factor (41) optional if 1
- Oblique angle (51) optional if 0
- Text style name (7) optional
- Text generation flags(71) optional if 0
- Horizontal justification type (72) optional if 0
- Vertical justification type (73) optional if 0

f EXTENDED entities – these consist of:

- Application name (1001)
- Control string (1002)
- String (1000) one or more
- Control string (1002)

Figure 5.12: Level 2

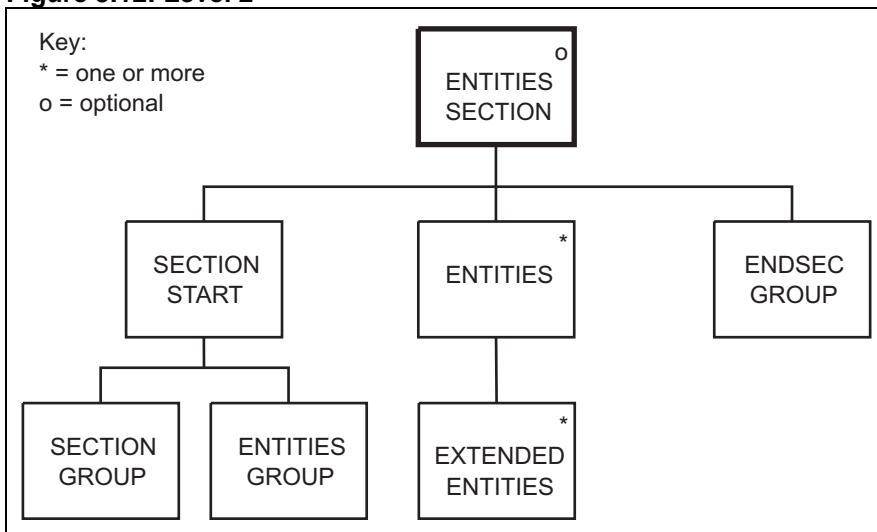

Figure 5.13: Level 3

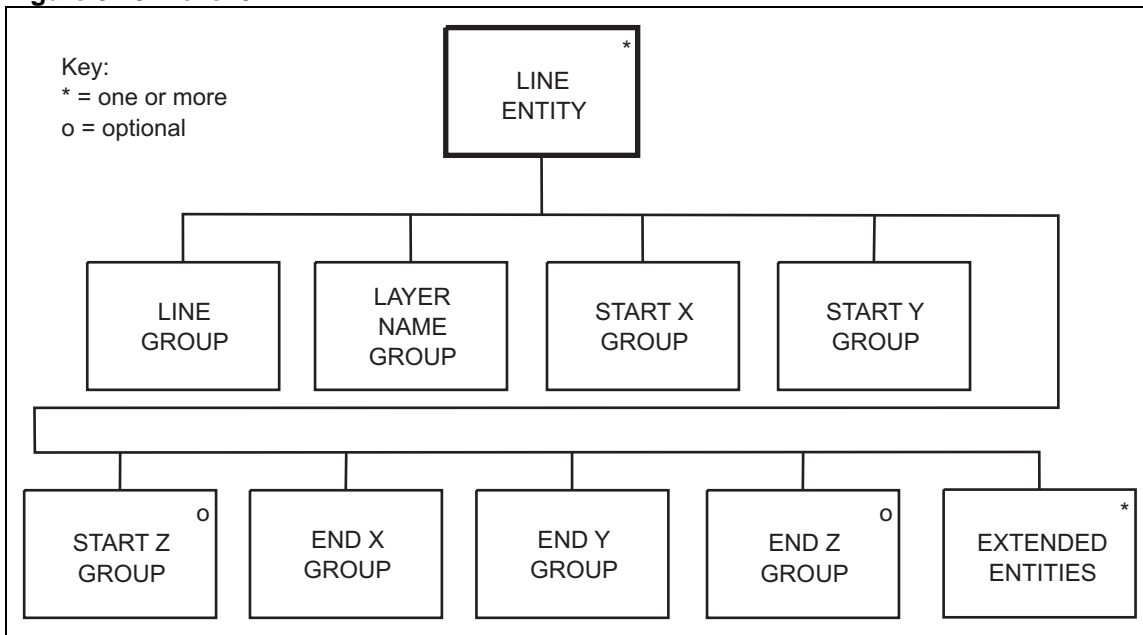

Figure 5.14: Level 3

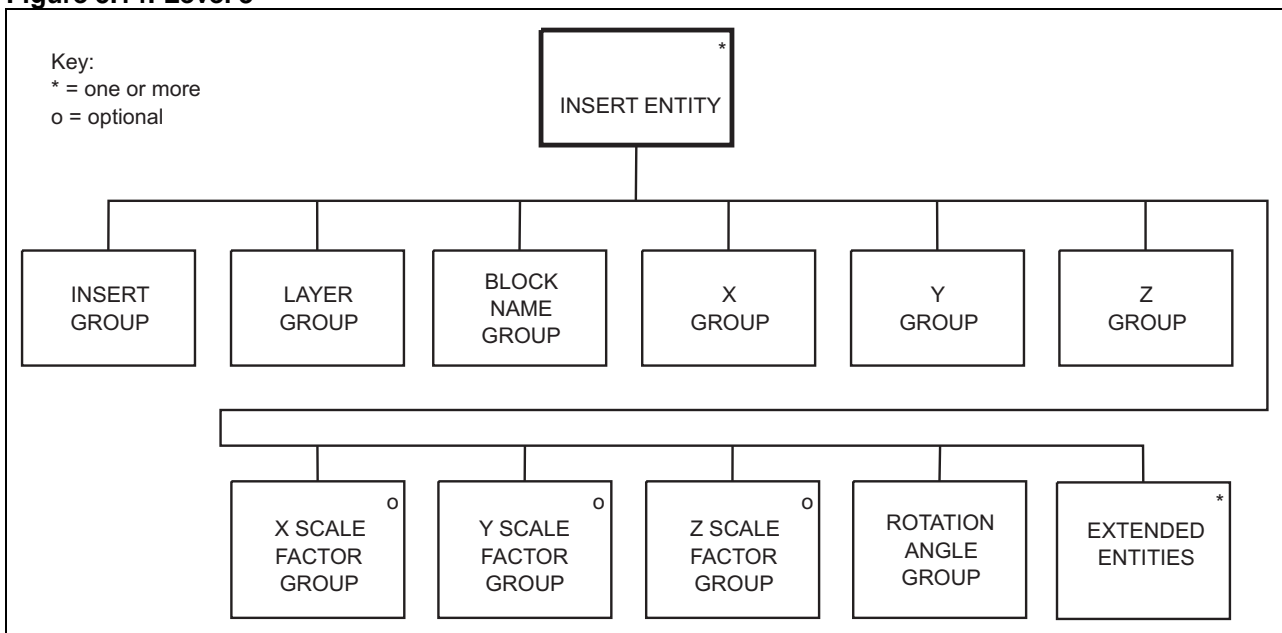

Figure 5.15: Level 3

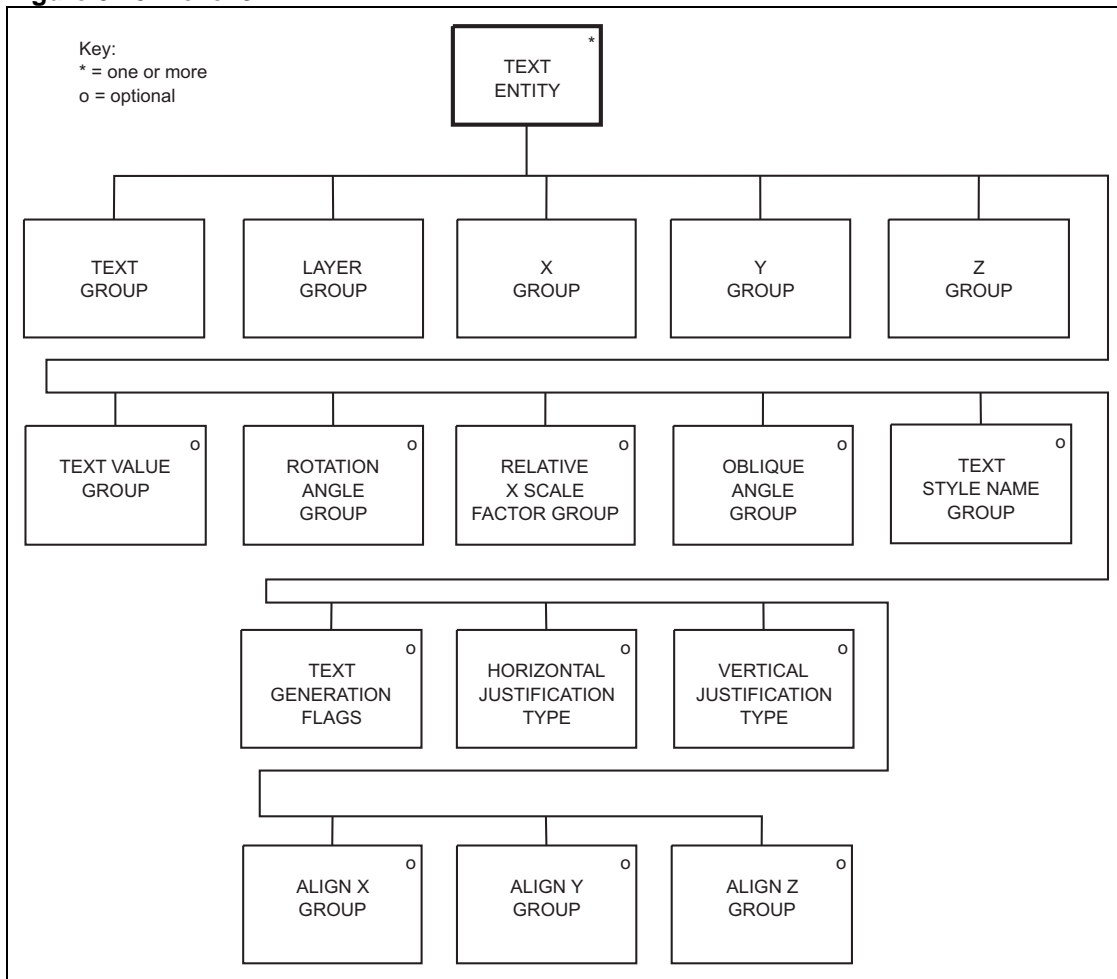

Figure 5.16: Level 3

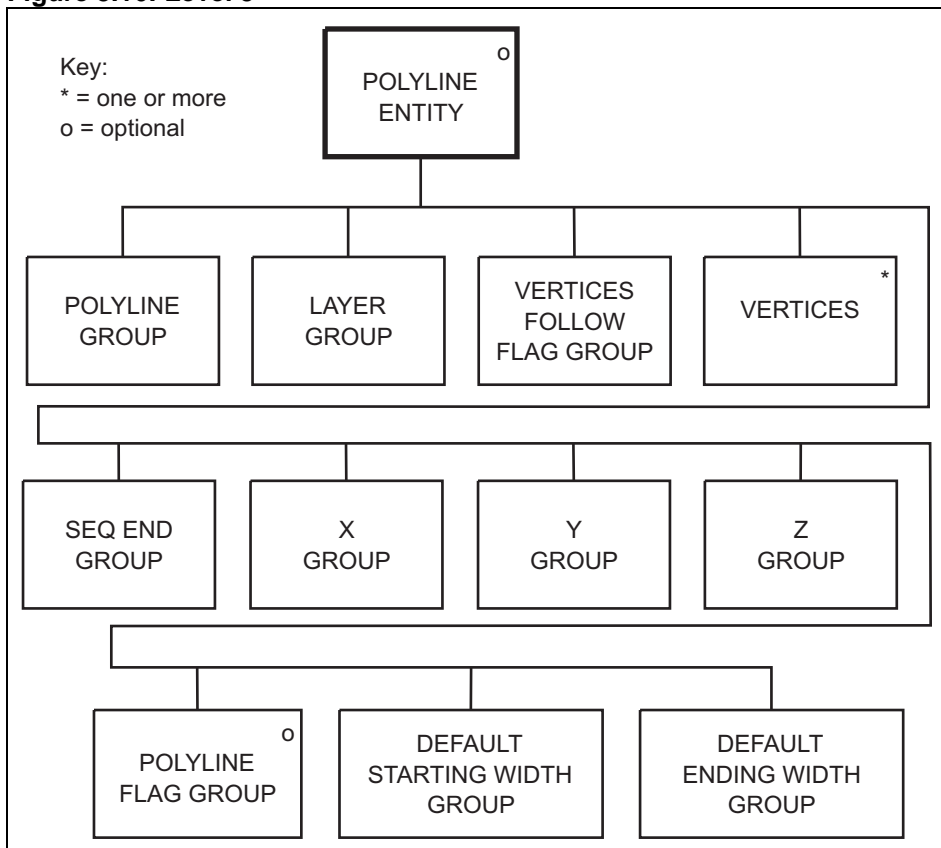
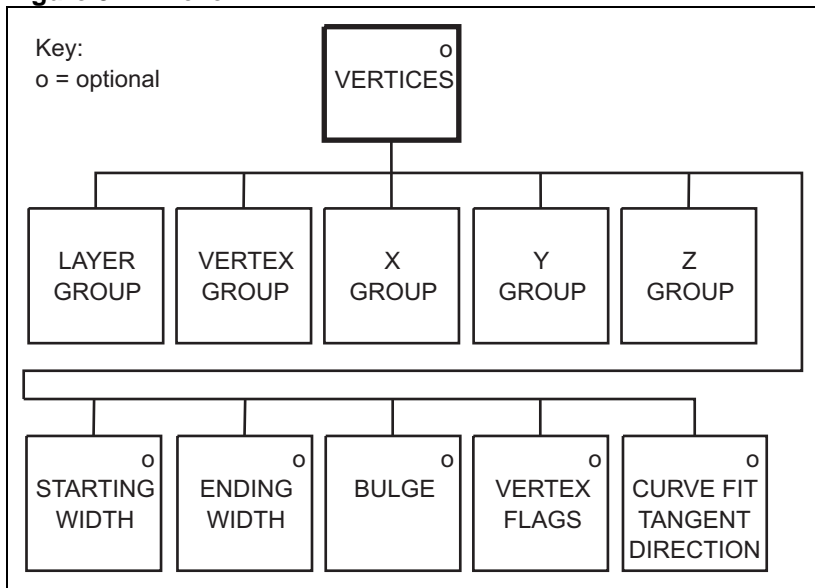

Figure 5.17: Level 4



End of file group

This group will end with DXF EOF (end of file) group.

Chapter 6 An overview of Strategi in Mid/Mif

Strategi is available in Mid/Mif

The transfer format is as defined by the [MapInfo Professional User's Guide](#):

'Mif Export – MapInfo Interchange Format (MIF) is an ASCII file format that can fully describe a MapInfo database. Both graphic and tabular data are exported into MIF files. The graphic data is in a file with a .mif extension, and the tabular data is in a file with a .mid extension. MIF files can be translated into other formats with other programs.'

An overview of the data structure of a Strategi file in Mid/Mif is shown below.

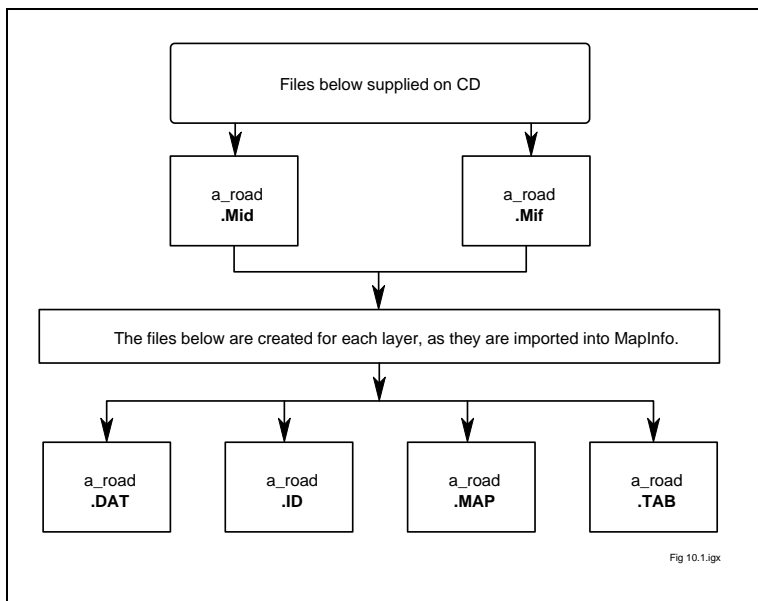

Once this is done, it is ready for use (the above example is for the A road layer).

Structure of Strategi in MapInfo

Strategi has a limited link-and-node data structure: within this structure a feature may be a name, a point or a line (or series of lines forming a coherent unit). Each feature is free-standing; that is, its topological relationship to any other feature is not expressed in the data.

Features are classified by type and each type is placed in a separate TAB layer.

Line features

A feature is a subjective entity; that is, so long as the constituent lines are the same description (layer), a feature need not fully describe a logical piece of detail.

The extent of a feature is determined by digitising conventions and does not always coincide with the topology. Each linear feature is composed of a string of XY coordinate pairs implicitly joined by straight lines.

The colour and line weights for the layers are defined by the parameter file shown in [Mid/Mif layers](#) later in this chapter.

Area features

Area features are polygons with attributes added.

Names features

Names features are treated as free-standing text data. There is no explicit relationship (in the data) between a text feature and the point or line feature to which it belongs.

Ordnance Survey distinguishes between layer name types – for example, place names and station names – by placing each name type in a separate layer.

Text has an anchor position, expressed as a single coordinate pair held as X and Y offsets from the map origin (south-west corner). If there are any double- or treble- banked names they will be treated as two or three separate features. Anchor points at the bottom left hand corner and digitising positions define the text string content. Text is oriented, that is, it may run from west to east across the map, or it may be plotted at some angle measured anticlockwise from grid east.

Drawing content and format

Coordinate system

The coordinate system is National Grid (NG).

The NG coordinates are to a resolution of 1 metre. This is the resolution of the source data.

Layer names

MapInfo supports long filenames. This allows you to use up to 260 characters when naming your file. In addition, any one name within your directory path can be up to 255 characters. You can insert spaces in the filename and long filenames can have more than one "." in them. When using more than one ".", you must remember to type in the file extension in order to save the file correctly. For example, you can name a table as follows: `\\saints\spirit.of.the.south.dbf`

Layer names were created and set when the original NTF data was translated (number of layers = 26). The *Strategi Import Parameters* in the translator highlights a feature code and allocates it to a layer. The logic behind which layer feature codes are allocated is due to the relationship of features.

Neatline

No neatline

Grid

5397 (100 km grid) 5398 (10 km grid)

Grid values

No grid values

Mid/Mif layers

This section contains a list of all the valid features used within Strategi. The list contains a description of each feature code, feature name, feature type and a list of the style information required to create an output. Each feature layer then contains other information as attributes.

Important information

Certain feature codes that are used and defined in NTF are not required or used in MapInfo.

Some examples of this are: 5494: Foreshore – sand inner limit, 5250: Lake/other inland water outer limit.

Other feature codes that are not used: 5120, 5121, 5495, 5122, 5123, 5490, 5251, 5492, 5421, 5420, 5493, 5423, 5422, 5491, 5611 and 5610.

Please note, null values in MID tables will be shown – 9999.

Note column	Meaning
o	Feature codes in NTF data, but no translation into MapInfo at present.
x	Feature code in NTF, translated into MapInfo.
e	Extra feature codes created in MapInfo.

1 Communications

Motorway

Feature code	Feature name	Folder	Type	Style	Note
5310	Motorway	motorway	Line	Pen (35,194,5278719)	x
5312	Motorway over other feature	motorway	Line	Pen (35,194,5278719)	x
5300	Motorway, under construction	motorway	Line	Pen (35,4,5278719)	x
5301	Motorway, under const over other feature	motorway	Line	Pen (35,4,5278719)	x
5311	Motorway, planned	motorway	Line	Pen (35,5,5278719)	x
5313	Motorway tunnel	motorway	Line	Pen (40,3,5278719)	x
5370	Motorway Junction	trans_pt	Font symbol	Symbol (63,7381247,8,"MapInfo Weather",16,0)	x
5371	Motorway Junction, limited access	trans_pt	Font symbol	Symbol (63,7381247,8,"MapInfo Weather",256,0)	x
5372	Motorway Junction, under construction	trans_pt	Font symbol	Symbol (58,7381247,8,"MapInfo Weather",256,0)	x

Primary routes

Feature code	Feature name	Folder	Type	Style	Note
5320	Primary Route, Dual Carriageway	primy_rd	Line	Pen (30,194,45056)	x
5322	Primary Route, D C'way over other feature	primy_rd	Line	Pen (30,194,45056)	x
5302	Primary Route, D C'way under construction	primy_rd	Line	Pen (35,4,45056)	x
5303	Primary Route, D C'way under const (over)	primy_rd	Line	Pen (35,4,45056)	x
5321	Primary Route, Dual Carriageway, planned	primy_rd	Line	Pen (35,5,45056)	x
5355	Roundabout, Primary Route Dual Carriageway	trans_pt	Symbol	Symbol (34,45056,6)	x
5323	Primary Route, Single Carriageway	primy_rd	Line	Pen (35,2,45056)	x
5325	Primary Route, S C'way over other feature	primy_rd	Line	Pen (35,2,45056)	x
5304	Primary Route, S C'way under construction	primy_rd	Line	Pen (30,9,45056)	x
5305	Primary Route, S C'way under const (over)	primy_rd	Line	Pen (30,9,45056)	x
5324	Primary Route, S Carriageway, planned	primy_rd	Line	Pen (30,11,45056)	x
5375	Roundabout, Primary Route Single C'way	trans_pt	Symbol	Symbol (34,45056,6)	x
5326	Primary Route, Narrow	primy_rd	Line	Pen (25,3,45056)	x
5327	Primary Route, Narrow over other feature	primy_rd	Line	Pen (25,3,45056)	x
5373	Primary Route tunnel	primy_rd	Line	Pen (25,10,45056)	x

Feature code	Feature name	Folder	Type	Style	Note
5360	Service station (full access)	trans_pt	Font symbol	Symbol (34,5278719,9,"MapInfo Symbols",16,82)	x
5361	Service station (limited access)	trans_pt	Font symbol	Symbol (34,5278719,9,"MapInfo Symbols",256,295.4)	x
5378	Multilevel Junction, under construction	trans_pt	Font symbol	Symbol (41,45056,8,"MapInfo Symbols",257,0)	x
5379	Multilevel Junction (full access)	trans_pt	Font symbol	Symbol (63,57344,8,"MapInfo Weather",16,0)	x
5389	Multilevel Junction (limited access)	trans_pt	Font symbol	Symbol (63,57344,8, "MapInfo Weather",256,0)	x
5392	Service Station (non-24 hour, primary and A roads only)	trans_pt	Font symbol	Symbol (34,57344,7, "MapInfo Symbol",16,0)	x

A roads

Feature code	Feature name	Folder	Type	Style	Note
5330	A Road, Dual Carriageway	a_road	Line	Pen (30,194,16711680)	x
5332	A Road, Dual C'way over other feature	a_road	Line	Pen (30,194,16711680)	x
5306	A Road, Dual C'way under construction	a_road	Line	Pen (25,4,16711680)	x
5307	A Road, Dual C'way under const (over)	a_road	Line	Pen (25,4,16711680)	x
5331	A Road, Dual Carriageway, planned	a_road	Line	Pen (25,5,16711680)	x
5356	Roundabout, A Road Dual Carriageway	trans_pt	Symbol	Symbol (34,16711680,6)	x
5333	A Road, Single Carriageway	a_road	Line	Pen (25,2,16711680)	x
5335	A Road, Single C'way over other feature	a_road	Line	Pen (25,2,16711680)	x
5308	A Road, Single C'way under construction	a_road	Line	Pen (20,9,16711680)	x
5309	A Road, Single C'way under const (over)	a_road	Line	Pen (20,9,16711680)	x
5334	A Road, Single Carriageway, planned	a_road	Line	Pen (20,11,16711680)	x
5376	Roundabout, A Road Single Carriageway	trans_pt	Symbol	Symbol (34,16711680,6)	x
5336	A Road, Narrow	a_road	Line	Pen (20,3,16711680)	x
5337	A Road, Narrow, over other feature	a_road	Line	Pen (20,3,16711680)	x
5358	A Road tunnel	a_road	Line	Pen (25,10,16711680)	x

B roads

Feature code	Feature name	Folder	Type	Style	Note
5340	B Road, Dual Carriageway	b_road	Line	Pen (30,194,16750640)	x
5342	B Road, Dual C'way over other feature	b_road	Line	Pen (30,194,16750640)	x
5357	Roundabout, B Road Dual Carriageway	trans_pt	Symbol	Symbol (34,16750640,6)	x
5343	B Road, Single Carriageway	b_road	Line	Pen (25,2,16750640)	x
5345	B Road, Single C'way over other feature	b_road	Line	Pen (25,2,16750640)	x
5377	Roundabout, B Road Single Carriageway	trans_pt	Symbol	Symbol (34,16750640,6)	x
5346	B Road, Narrow	b_road	Line	Pen (20,3,16750640)	x
5347	B Road, Narrow, over other feature	b_road	Line	Pen (20,3,16750640)	x
5359	B Road tunnel	b_road	Line	Pen (25,10,16750640)	x

Minor roads – over 4 metres wide

Feature code	Feature name	Folder	Type	Style	Note
5350	Minor Road over 4 metres wide	minor_rd	Line	Pen (20,2,10526880)	x
5351	Minor Road over 4 metres wide (over)	minor_rd	Line	Pen (20,2,10526880)	x
5374	Roundabout, Minor Road over 4 metres wide	trans_pt	Symbol	Symbol (34,0,5)	x
5353	Minor Road over 4 metres wide tunnel	minor_rd	Line	Pen (20,10,10526880)	x

Minor roads – under 4 metres wide

Feature code	Feature name	Folder	Type	Style	Note
5405	Minor Road under 4 metres wide	minor_rd	Line	Pen (17,2,10526880)	x
5406	Minor Road under 4 metres wide (over)	minor_rd	Line	Pen (17,2,10526880)	x
5408	Roundabout, Minor Road under 4 metres wide	trans_pt	Symbol	Symbol (34,0,5)	x
5407	Minor Road under 4 metres wide tunnel	minor_rd	Line	Pen (17,10,10526880)	x
5403	Dead-end Road gen under 4 metres wide	minor_rd	Line	Pen (17,2,10526880)	x
5404	Dead-end Road gen < 4 metres wide (over)	minor_rd	Line	Pen (17,2,10526880)	x
5384	Other Track or Road	minor_rd	Line	Pen (15,3,10526880)	x
5385	Other Track or Road over other feature	minor_rd	Line	Pen (15,3,10526880)	x
5381	Roundabout under construction	trans_pt	Symbol	Symbol (40,0,5)	x

Feature code	Feature name		Type	Style	Note
5380	Gradient, 1 in 7 or Steeper	trans_pt	Font symbol	Symbol (217,0,10,"Wingdings",0,0)	x
5314	Road Tunnel (end symbol)	trans_pt	Font symbol	Symbol (113,0,8,"MapInfo Cartographic",0,0)	x
5382	Toll Bar (all roads)	trans_pt	Font symbol	Symbol (76,0,8,"MapInfo Cartographic",0,0)	x

Railways

Feature code	Feature name	Folder	Type	Style	Note
5510	Railway, Standard Gauge	railway	Line	Pen (25,2,0)	x
5511	Railway, Standard Gauge over other feature	railway	Line	Pen (30,2,0)	x
5512	Railway, Narrow Gauge	railway	Line	Pen (17,2,0)	x
5513	Railway, Narrow Gauge over other feature	railway	Line	Pen (20,2,0)	x
5514	Railway, Tunnel	railway	Line	Pen (25,3,0)	x
5519	Railway, Standard Gauge under construction	railway	Line	Pen (25,5,0)	x
5520	Railway Station	trans_pt	Symbol	Symbol (34,16711680,12)	x
5521	Rapid Transit Station	trans_pt	Symbol	Symbol (34,16711680,7)	x
5522	Rapid Transit Line	railway	Line	Pen (20,2,0)	x
5523	Rapid Transit Line (over)	railway	Line	Pen (20,2,0)	x
5524	Rapid Transit Tunnel	railway	Line	Pen (20,3,0)	x
5525	Rapid Transit Line (U/C)	railway	Line		o
5530	Level Crossing on Classified Road	trans_pt	Font symbol	Symbol (51,0,7,"MapInfo Symbols",257,20.4)	x
5531	Level Crossing on Unclassified Road	trans_pt	Font symbol	Symbol (51,0,7,"MapInfo Symbols",256,135)	x

Airport

Feature code	Feature name	Folder	Type	Style	Note
5839	Airport Non Sch with Permanent Customs	airport	Font symbol	Symbol (72,128,11,"MapInfo Real Estate",0,0)	x
5840	Airport (No Customs facilities)	airport	Font symbol	Symbol (53,128,10,"MapInfo Symbols",0,0)	x
5841	Airport (Customs facilities)	airport	Font symbol	Symbol (72,128,14,"MapInfo Real Estate",0,0)	x

Heliport

Feature code	Feature name	Folder	Type	Style	Note
5845	Heliport	airport	Font symbol	Symbol (91,128,12,"MapInfo Transportation",0,0)	x

Ferries

Feature code	Feature name	Folder	Type	Style	Note
5390	Vehicular Ferry Route	ferry	Line	Pen (20,6,8421504)	x
5393	Ferry Route Link	ferry	Line	Pen (20,6,8421504)	x

National trails, long distance path and route

Feature code	Feature name	Folder	Type	Style	Note
5825	Long Distance Footpath	minor_rd	Line	Pen (20,5,8421504)	x

2 Water features

Coastline

Feature code	Feature name	Folder	Type	Style	Note
5110	Coastline (Natural)	coast	Line	Pen (17,2,4227327)	x

Sea area seed (below MHW)

Feature code	Feature name	Folder	Type	Style	Note
5115	Sea Seed below Mean High Water	seeds	Font symbol	Symbol (50,255,6,"MapInfo Symbols",0,0)	x

Foreshore area

Feature code	Feature name	Folder	Type	Style	Note
5120	Foreshore – sand outer limit	forshor	Line	Pen (1,2,0)	o
5494	Foreshore – sand inner limit	<i>Not used</i>	Line	Pen (1,2,0)	x
5120	Foreshore – sand polygon	forshor	Polygon	Pen (1,1,0) Brush(2,16777104,16777215)	e
5121	Foreshore – sand seed	<i>Not used</i>	Symbol	Symbol (49,0,12)	x
5122	Foreshore – other MLW exposed outer limit	forshor	Line	Pen (1,2,0)	o
5495	Foreshore – other MLW exposed inner limit	<i>Not used</i>	Line	Pen (1,2,0)	x
5122	Foreshore – other MLW exposed polygon	forshor	Polygon	Pen (1,1,0) Brush(49,8421504)	e
5123	Foreshore – other seed	<i>Not used</i>	Symbol	Symbol (49,0,12)	x

River – primary

Feature code	Feature name	Folder	Type	Style	Note
5211	Main River, Source	rivers	Line	Pen (20,2,4243711)	x
5212	Main River, Middle	rivers	Line	Pen (25,2,4243711)	x
5213	Main River, Lower	rivers	Line	Pen (30,2,4243711)	x

River – secondary

Feature code	Feature name	Folder	Type	Style	Note
5221	Secondary River, Source	rivers	Line	Pen (20,2,4243711)	x
5222	Secondary River, Lower	rivers	Line	Pen (25,2,4243711)	x

Other river and drains

Feature code	Feature name	Folder	Type	Style	Note
5230	Minor River	rivers	Line	Pen (20,2,4243711)	x

Canal

Feature code	Feature name	Folder	Type	Style	Note
5240	Canal	rivers	Line	Pen (15,2,65535)	x
5242	Canal, over other feature	rivers	Line	Pen (17,2,65535)	x
5241	Canal Tunnel	rivers	Line	Pen (15,10,65535)	x

Inland water (lake, reservoir, loch, pond, shoreline and so on)

Feature code	Feature name	Folder	Type	Style	Note
5250	Lake/other inland water outer limit	lakes	Line	Pen (1,2,255)	o
5490	Lake/other inland water inner limit	<i>Not used</i>	Line	Pen (1,2,255)	x
5251	Lake/other inland water seed	<i>Not used</i>	Symbol	Symbol (49,4227327,12)	x
5250	Lake/other inland water polygon	<i>Not used</i>	Polygon	Pen (12,2,65535)Brush (2,11593215,16777215)	e

Lighthouse

Feature code	Feature name	Folder	Type	Style	Note
5140	Lighthouse (in use)	water_ft	Font symbol	Symbol (113,128,14,"MapInfo Transportation",0,0)	x
5142	Lighthouse (disused)	water_ft	Font symbol	Symbol (114,128,14,"MapInfo Transportation",0,0)	x

Lightship

Feature code	Feature name	Folder	Type	Style	Note
5141	Lightship	water_ft	Font symbol	Symbol (106,128,12,"MapInfo Transportation",0,0)	x

3 Settlements

Settlement attribute points

Feature code	Feature name	Folder	Type	Style	Note
5427	City Attribute Point	settlmnt	Symbol	Symbol (32,16776960,9)	x
5413	Town Attribute Point	settlmnt	Symbol	Symbol (32,16776960,8)	x
5416	Village Attribute Point	settlmnt	Symbol	Symbol (32,16776960,6)	x
5419	Landmark Attribute Point	settlmnt	Font symbol	Symbol (112,128,8,"MapInfo Cartographic",0,0)	x

Urban area

Feature code	Feature name	Folder	Type	Style	Note
5420	Large Urban Area outer limit	<i>Not used</i>	Line	Pen (1,2,0)	o
5492	Large Urban Area inner limit	<i>Not used</i>	Line	Pen (1,2,0)	x
5421	Large Urban Area seed	<i>Not used</i>	Symbol	Symbol (49,16711680,12)	x
5420	Large Urban Area polygon	<i>Not used</i>	Polygon	Pen (1,1,0) Brush (2,16762032,16777215)	e
5422	Small Urban Area outer limit	<i>Not used</i>	Line	Pen (1,2,0)	o
5493	Small Urban Area inner limit	<i>Not used</i>	Line	Pen (1,2,0)	x
5423	Small Urban Area seed	<i>Not used</i>	Symbol	Symbol (49,16711680,12)	x
5422	Small Urban Area polygon	<i>Not used</i>	Polygon	Pen (1,1,8421504) Brush (2,16762032,16777215)	e

4 Boundaries

Feature code	Feature name	Folder	Type	Style	Note
5710	National Boundary	admin	Line	Pen (25,23,0)	x
5715	National Primary Attribute Point	admin	Font symbol	Symbol (52,0,6,"MapInfo Symbols",1,0)	x
5720	County Boundary	admin	Line	Pen (17,23,0)	x
5725	County Primary Attribute Point	admin	Font symbol	Symbol (52,0,6,"MapInfo Symbols",0,0)	x
5740	Unitary Boundary	admin	Line	Pen (17,24,0)	x
5744	Unitary Primary Attribute Point	admin	Font symbol	Symbol (51,0,6,"MapInfo Symbols",1,0)	x
5730	District Boundary	admin	Line	Pen (17,24,0)	x
5733	District Primary Attribute Point	admin	Font symbol	Symbol (51,0,6,"MapInfo Symbols",0,0)	x
5750	Associated Area Boundary	admin	Line	Pen (17,23,0)	x
5734	Administrative Detached Attribute Point	admin	Font symbol	Symbol (50,0,6,"MapInfo Symbols",0,0)	x
5820	National Park/Forest Park Boundary	nat_park	Line	Pen (25,3,32896)	x
5821	National Park/Forest Park Seed	nat_park	Font symbol	Symbol (50,32896,6,"MapInfo Symbols",0,0)	x

5 Land use

Feature code	Feature name	Folder	Type	Style	Note
5610	Wood/Forest outer limit	woodland	Line	Pen (1,2,32896)	o
5491	Wood/Forest inner limit	<i>Not used</i>	Line	Pen (1,2,32896)	x
5611	Wood/Forest seed	<i>Not used</i>	Symbol	Symbol (49,0,12)	x
5610	Wood/Forest polygon	<i>Not used</i>	Polygon	Pen (1,1,32896) Brush (2,11599792,16777215)	e
5612	Marsh	water_ft	Font symbol	Symbol (109,32896,12,"MapInfo Cartographic",0,0)	x
5621	Island Area Attribute Point	land_use	Font symbol	Symbol (51,16711680,6,"MapInfo Symbols",0,0)	x
5620	Geographical Area Attribute Point	land_use	Font symbol	Symbol (50,16711680,6,"MapInfo Symbols",0,0)	x

6 Other features

Antiquities

Feature code	Feature name	Folder	Type	Style	Note
5810	Roman Road	land_use	Line	Pen (15,5,8388608)	x
5812	Antiquity Line Detail (dyke, wall, and so on)	land_use	Line	Pen (1,2,8388608)	x
5815	Hill Fort	land_use	Font symbol	Symbol (122,128,10,"MapInfo Miscellaneous",0,0)	x
5816	Battlefield	land_use	Font symbol	Symbol (118,128,12,"MapInfo Miscellaneous",0,0)	x

Others

Feature code	Feature name	Folder	Type	Style	Note
5838	Landmark/Antiquity dot	tourist	Font symbol	Symbol (35,8388608,4,"MapInfo Symbols",0,0)	x
5837	Telephone Dot	tourist	Font symbol	Symbol (35,128,4,"MapInfo Symbols",0,0)	x
5835	Television, Radio Mast or Tower	land_use	Font symbol	Symbol (80,128,12,"MapInfo Real Estate",0,0)	x
5843	Wind Powered Generator	land_use	Font symbol	Symbol (82,128,12,"MapInfo Real Estate",0,0)	x
5844	Windmill	land_use	Font symbol	Symbol (79,128,12,"MapInfo Real Estate",0,0)	x

Tourist

Feature code	Feature name	Folder	Type	Style	Note
5860	Abbey, Cathedral, Priory (open to the public)	tourist	Font symbol	Symbol (69,128,12,"MapInfo Real Estate",0,0)	x
5875	Aquarium (open to the public)	tourist	Font symbol	Symbol (120,128,12,"MapInfo Miscellaneous",0,0)	x
5805	Camping and Caravanning Combined Site	tourist	Font symbol	Symbol (66,128,12,"MapInfo Miscellaneous",0,0)	x
5861	Camp Site	tourist	Font symbol	Symbol (58,128,12,"MapInfo Symbols",0,0)	x
5862	Caravan Site	tourist	Font symbol	Symbol (66,128,9,"MapInfo Miscellaneous",0,0)	x
5877	Castle (open to the public)	tourist	Font symbol	Symbol (68,128,14,"MapInfo Real Estate",0,0)	x
5876	Cave (open to the public)	tourist	Font symbol	Symbol (121,128,12,"MapInfo Miscellaneous",0,0)	x
5867	Country Park (open to the public)	tourist	Font symbol	Symbol (64,128,12,"MapInfo Miscellaneous",0,0)	x
5873	Craft Centre (open to the public)	tourist	Font symbol	Symbol (35,128,12,"MapInfo Real Estate",0,0)	x
5890	Ferry Box Outline	txtrans	Font symbol	Pen (15,2,128)	x
5887	Ferry Boat	tourist	Font symbol	Symbol (107,128,14,"MapInfo Transportation",0,0)	x
5892	Ferry Catamaran	tourist	Font symbol	Symbol (101,128,14,"MapInfo Transportation",0,0)	x
5888	Ferry Hovercraft	<i>Not used</i>	Font symbol	Symbol (108,128,14,"MapInfo Transportation",0,0)	x
5886	Garden (open to the public)	tourist	Font symbol	Symbol (124,128,12,"MapInfo Miscellaneous",0,0)	x
5863	Golf Course	tourist	Font symbol	Symbol (33,128,18,"MapInfo Miscellaneous",1,0)	x
5878	Historic House (open to the public)	tourist	Font symbol	Symbol (36,128,10,"MapInfo Real Estate",0,0)	x
5879	Motor Racing Circuit	tourist	Font symbol	Symbol (125,128,12,"MapInfo Miscellaneous",0,0)	x
5864	Museum (open to the public)	tourist	Font symbol	Symbol (119,128,12,"MapInfo Miscellaneous",0,0)	x
5869	Nature or Forest Trail	tourist	Font symbol	Symbol (59,128,12,"MapInfo Miscellaneous",0,0)	x
5880	Nature Reserve	tourist	Font symbol	Symbol (136,128,12,"MapInfo Miscellaneous",0,0)	x
5883	Other Tourist Attract (open to the public)	tourist	Font symbol	Symbol (117,128,12,"MapInfo Miscellaneous",0,0)	x
5806	Park and Ride	tourist	Font symbol	Symbol (80,128,12,"MapInfo Transportation",0,0)	x
5865	Picnic Site	tourist	Font symbol	Symbol (68,128,12,"MapInfo Miscellaneous",0,0)	x
5871	Preserved Railway	tourist	Font symbol	Symbol (130,128,12,"MapInfo Miscellaneous",0,0)	x
5885	Racecourse	tourist	Font symbol	Symbol (131,128,14,"MapInfo Miscellaneous",0,0)	x

Feature code	Feature name	Folder	Type	Style	Note
5884	Ski Slope	tourist	Font symbol	Symbol (80,128,14,"MapInfo Miscellaneous",0,0)	x
5849	Motoring Organisation Telephone	<i>Not used</i>	Font symbol	Symbol (116,8388608,12,"MapInfo Transportation",0,0)	x
5847	Public Telephone	tourist	Font symbol	Symbol (116,128,12,"MapInfo Transportation",0,0)	x
5851	Theme Park (open to the public)	tourist	Font symbol	Symbol (40,128,12,"MapInfo Real Estate",0,0)	x
5866	Tourist Info Centre (open all year)	tourist	Font symbol	Symbol (47,128,12,"MapInfo Transportation",0,0)	x
5889	Tourist Info Centre (seasonal)	tourist	Font symbol	Symbol (46,128,12,"MapInfo Transportation",0,0)	x
5882	Viewpoint (360 degrees)	tourist	Font symbol	Symbol (134,128,14,"MapInfo Miscellaneous",0,0)	x
5881	Viewpoint (Limited)	tourist	Font symbol	Symbol (135,128,14,"MapInfo Miscellaneous",0,90)	x
5874	Wildlife Centre (open to the public)	tourist	Font symbol	Symbol (79,128,12,"MapInfo Miscellaneous",0,0)	x
5868	Youth Hostel	tourist	Font symbol	Symbol (64,128,12,"MapInfo Real Estate",0,0)	x
5870	Zoo (open to the public)	tourist	Font symbol	Symbol (137,128,12,"MapInfo Miscellaneous",0,0)	x

Height

Feature code	Feature name	Folder	Type	Style	Note
5901	Spot Height dot	seeds	Point	Symbol (50,16750848,5,"MapInfo Symbols",0,0)	x

7 Miscellaneous

Feature code	Feature name	Folder	Type	Style	Note
5397	100 km Accentuated Grid Line	gridline	Line	Pen (12,2,65535)	x
5398	10 km Grid Line	gridline	Line	Pen (12,3,65535)	x

8 Geographic text

Primary route destination

Feature code	Feature name	Folder	Type	Style	Note
5025	Graphic Text, City (Primy Rte Dest)	txtother	Text	Font ("Arial",257,0,0,11599792)	x
5041	Graphic Text, Town (Primy Rte Dest)	txtother	Text	Font ("Arial",257,0,0,11599792)	x
5049	Graphic Text, Village (Primy Rte Dest)	txtother	Text	Font ("Arial",257,0,0,11599792)	x

Non-primary route destination

Feature code	Feature name	Folder	Type	Style	Note
5026	Graphic Text, City (Not Primy Rte Dest)	txtother	Text	Font ("Arial",257,0,0,16777215)	x
5006	Graphic Text, Town (Not Primy Rte Dest)	txtother	Text	Font ("Arial",257,0,0,16777215)	x
5040	Graphic Text, Village (Not Primy Rte Dest)	txtother	Text	Font ("Arial",257,0,0,16777215)	x

Road numbers

Feature code	Feature name	Folder	Type	Style	Note
5031	Graphic Text, Motorway Number	txtttrans	Text	Font ("Arial",1,0,16777215,255)	x
5032	Graphic Text, Primy Route Number	txtttrans	Text	Font ("Arial",1,0,16776960,32768)	x
5033	Graphic Text, A Road Number	txtttrans	Text	Font ("Arial",256,0,16711680,16777215)	x
5034	Graphic Text, B Road Number	txtttrans	Text	Font ("Arial",256,0,13671424,16777215)	x

Dual junction divider line

Feature code	Feature name	Folder	Type	Style	Note
5109	Dual Junction Graphic Text Divider Line	txtttrans	Font symbol	Symbol (51,255,9,"MapInfo Transportation",0,270)	x

Motorway junction numbers

Feature code	Feature name	Folder	Type	Style	Note
5042	Graphic Text, Mway Junc No (Full Access)	txtttrans	Text	Font ("Arial",257,0,16777215,255)	x
5043	Graphic Text, Mway Junc No (Ltd Access)	txtttrans	Text	Font ("Arial",257,0,16777215,255)	x
5048	Graphic Text, Services	txtttrans	Text	Font ("Arial",0,0,0)	x

Toll

Feature code	Feature name	Folder	Type	Style	Note
5038	Graphic Text, Toll	txtttrans	Text	Font ("Arial",2,0,0)	x

Road distance mileage

Feature code	Feature name	Folder	Type	Style	Note
5036	Graphic Text, Road Distance (Motorway)	txtttrans	Text	Font ("Arial",3,0,8388736)	x
5037	Graphic Text, Road Distance (Primary and A)	txtttrans	Text	Font ("Arial",258,0,8388736,16777215)	x

Road distance marker

Feature code	Feature name	Folder	Type	Style	Note
5108	Road Distance Marker (Motorway)	trans_pt	Font symbol	Symbol (33,8388736,18,"MapInfo Miscellaneous",1,277.7)	x
5107	Road Distance Marker (Primary & A)	trans_pt	Font symbol	Symbol (33,8388736,14,"MapInfo Miscellaneous",0,340.8)	x

Geographical area names

Feature code	Feature name	Folder	Type	Style	Note
5060	Graphic Text, Geographical Area	txtother	Text	Font ("Times New Roman",1027,0,8388608)	x

Large hills, ranges and summits

Feature code	Feature name	Folder	Type	Style	Note
5061	Graphic Text, Large Hills and Ranges	txtother	Text	Font ("Times New Roman",3,0,0)	x

Named hills, islands and rocks

Feature code	Feature name	Folder	Type	Style	Note
5062	Graphic Text, Hills, Islands and Rocks	txtother	Text	Font ("Times New Roman",2,0,0)	x

Other text

Feature code	Feature name	Folder	Type	Style	Note
5016	Graphic Text, Other	txtother	Text	Font ("Times New Roman",0,0,8388608,-1)	x

Water features

Feature code	Feature name	Folder	Type	Style	Note
5020	Graphic Text, Water Feature	txtother	Text	Font ("Times New Roman",2,0,255)	x

Tourist feature

Feature code	Feature name	Folder	Type	Style	Note
5044	Graphic Text, Tourist Feature	txtother	Text	Font ("Times New Roman",0,0,0)	x

Ferry annotation

Feature code	Feature name	Folder	Type	Style	Note
5039	Graphic Text, Ferry Annotation	txtrans	Text	Font ("Arial",1,0,128)	x

National trails, long distance path and route

Feature code	Feature name	Folder	Type	Style	Note
5045	Graphic Text, Long Distance Footpath	txttrans	Text	Font ("Arial",2,0,8421504)	x

National Park, forest park

Feature code	Feature name	Folder	Type	Style	Note
5046	Graphic Text, National Park/Forest Park	txtother	Text	Font ("Times New Roman",1025,6,32896)	x

Spot height values

Feature code	Feature name	Folder	Type	Style	Note
5090	Graphic Text, Spot Height Values	txtother	Text	Font ("Arial",1,0,16750848)	x

Antiquities

Feature code	Feature name	Folder	Type	Style	Note
5081	Graphic Text, Roman Antiquity	txtother	Text	Font ("Monotype Corsiva",0,0,8421504)	x
5082	Graphic Text, Non-Roman Antiquity	txtother	Text	Font ("Times New Roman",0,0,8421504)	x

County name

Feature code	Feature name	Folder	Type	Style	Note
5721	Graphic Text, County Name	txtadmin	Text	Font ("Arial",1026,0,32896)	x

Unitary authority name

Feature code	Feature name	Folder	Type	Style	Note
5741	Graphic Text, Unitary Name	txtadmin	Text	Font ("Arial",1026,0,32896)	x

District name

Feature code	Feature name	Folder	Type	Style	Note
5731	Graphic Text, District Name	txtadmin	Text	Font ("Arial",1026,0,32896)	x

Other codes – miscellaneous

Feature code	Feature name	Folder	Type	Style	Note
5200	Unspecified Node	seeds	Font symbol	Symbol (50,8421504,5,"MapInfo Symbols",0,0)	x

MIF file header information

The MIF file header will conform to the following convention:

```
Version 450
Charset "WindowsLatin1"
Delimiter ","
CoordSys Earth Projection 8, 79, "m", -2, 49, 0.9996012717, 400000, -100000
Bounds (-7845061.1011, -15524202.1641) (8645061.1011, 4470074.53373)
Columns 27
```

Attribution

The 27 columns mentioned above will contain the following attribution where the information relevant for the attribution is present. Numbers in brackets indicate the maximum number of characters allowed in that particular column:

Feature_Code Smallint	Ferry_To Char(50)	Owner Char(60)
Legend Char(42)	Ferry_Time Char(10)	Restrictions_North Char(60)
File_Name Char(16)	Ferry_Type Char(20)	Restrictions_South Char(60)
Feature_Serial_Number Integer	Ferry_Restrictions Char(20)	Restrictions_East Char(60)
Name Char(180)	Ferry_Access Char(30)	Restrictions_West Char(60)
Number Char(64)	Date_Last_Amended Date	Restrictions_Clockwise Char(60)
Admin_Name Char(50)	Usage Char(64)	Restrictions_Anticlockwise Char(60)
Airport_type Char(40)	Location Char(30)	Height_Imperial Smallint
Ferry_From Char(50)	GIS Char(80)	Height_Metric Smallint

Chapter 7 An overview of Strategi in ESRI Shapefile

ESRI® Shapefiles are a simple, non-topological format for storing the geometric location and attribute information of geographic features. A Shapefile is one of the spatial data formats that you can work with in ArcView GIS.

The Shapefile format defines the geometry and attributes of geographically-referenced features in as many as five files with specific file extensions that should be stored in the same project workspace. They are:

.shp – the file that stores the feature geometry.

.shx – the file that stores the index of the feature geometry.

.dbf – the dBASE file that stores the attribute information of features. When a Shapefile is added as a theme to a view, this file is displayed as a feature table.

.sbn and **.sbx** – the files that store the spatial index of the features. These two files may not exist until you perform theme-on-theme selection, spatial join, or create an index on a theme's shape field. If you have write access to the source data directory, the index files will be persistent and remain after your ArcView session is complete. If you do not have write access to the source data directory, they will be removed when you close the project or exit ArcView.

.ain and **.aih** – the files that store the attribute index of the active fields in a table or a theme's attribute table. These two files may not exist until you perform link on the tables. If you have write access to the source data directory, the index files will be persistent and remain after your ArcView session is complete. If you do not have write access to the source data directory, they will be removed when you close the project or exit ArcView.

ArcView will display Shapefiles (and ARC coverages) with a random point/line/region/text style each time they are opened. ArcView legend files can therefore be created to enable the data to be displayed with the same symbology whenever it is displayed. When using a legend file it is possible to display the features in a theme based on one of the theme's attributes (this essentially creates a thematic or unique values map). In a unique values map, a different colour is used to symbolise each value in an attribute.

Please see the table below for an overview of how the different features in Strategi are displayed (all themes using unique value legends will be displayed according to their feature code attribute).

In order for the legend files to work, they must have the same filename as the Shapefiles to which they correspond, for example, 'motorway.shp' must have a legend file called 'motorway.avl'.

For structure as MID/MIF and also drawing content and format as MID/MIF, see [chapter 6](#).

Shapefile attribution

The Shape file equivalents to the MID/MIF files (see previous chapter) are:

CODE	Long	FERRY_TO	String(50)	OWNER	String(60)
LEGEND	String(42)	FERRY_TIME	String(50)	NORTH	String(60)
FILE_NAME	String(16)	FERRY_TYPE	String(20)	SOUTH	String(60)
NUMBER	Double	RESTRICTIO	String(20)	EAST	String(60)
NAME	String(180)	ACCESS	String(30)	WEST	String(60)
NUMBER0	String(64)	AMENDED	Date	CLOCKWISE	String(60)
ADMIN_NAME	String(50)	USAGE	String(64)	ANTICLOCKW	String(60)
TYPE	String(40)	LOCATION	String(30)	IMPERIAL	Long
FERRY_FROM	String(50)	GIS	String(80)	METRIC	Long

Annexe A Data labels and layer descriptions

Data label	Layer description
A_road	A roads
Admin	Administrative boundaries
Airport	Airports
B_road	B roads
Coast	Coastline
Ferry	Ferry routes
Foreshore	Foreshore areas
Gridline	100 Km grid and 10 Km grid
Lakes	Inland water
Land_use	Geographical area (moors, headlands, fens and so on)
Minor_rd	Minor roads
Motorway	Motorways
Nat_park	National Forest park boundary
Primry_rd	Primary roads
Railway	Railways and rapid transits
Rivers	Rivers, canals
Seeds	Seed points
Settlmnt	Settlements seeds
Tourist	Tourist symbols
Trans_pt	Transition points, for example, roundabouts, limited access, road distance markers
Txtadmin	Administrative area text
Txtother	Descriptive names, for example, water, town, hills
Txttrans	Transitional points text, for example, road names and numbers
Urban	Urban areas
Water_ft	Canals, sea areas, lighthouses
Woodland	Woods, forests

B Glossary

absolute accuracy

A measure that indicates how closely the coordinates of a point in Ordnance Survey map data agree with the true National Grid coordinates of the same point on the ground.

As the true position can never be known exactly, the statistic is quoted relative to the best known position determined by precise survey methods.

absolute coordinates

A coordinate pair or triplet measured directly from the origin of the coordinate system in which it lies and not to any other point in the system.

accuracy

The closeness of the results of observations, computations or estimates to the true values or the values accepted as being true. Accuracy relates to the exactness of the result, and is a measure of the exactness of the operation by which the result is obtained.

administrative area

A term used by Ordnance Survey to refer to all public administrative areas, specifically, local government management and electoral areas.

area

A spatial extent defined by circumscribing lines that form a closed perimeter that does not intersect itself.

area seed

A point within an area that can be used to carry the attributes of the whole area, for example, ownership, address and use type.

ASCII (American Standard Code for Information Interchange)

A 7-bit code for encoding a standard character set.

attribute

An attribute is a property of an entity, usually used to refer to a non-spatial qualification of a spatially referenced entity. For example, a descriptive code indicating what an entity represents or how it should be portrayed.

attribute class

A specific group of attributes, for example, those describing measure, serviceability, structure or composition.

attribute code

An alphanumeric identifier for an attribute type.

attribute value

A specific quality or quantity assigned to an attribute.

bearing

Bearings are angles measured against the National Grid in degrees. They are measured clockwise from grid north.

block

A DXF term used to describe annotated or grouped lines, for example, defined symbols

boundary

A boundary is the limit of a predefined and established area whose limit is determined by one or more [lines](#), for example, county area boundary and reservoir boundary.

byte

A unit of computer storage, of binary data usually comprising 8 bits, equivalent to a character. Hence, megabyte (one million bytes) and gigabyte (one thousand million bytes).

Cartesian axes

A Cartesian coordinate system identifies a point on a plane using a pair of numerical coordinates. The point is identified when its perpendicular distance to the right of a vertical axis and its perpendicular distance above a horizontal axis are measured or known using the same unit of length.

cartography

The organisation and communication of geographically-related information in either graphic or digital form. It can include all stages from data acquisition to presentation and use.

CD-ROM

A data storage medium. A 12 cm disc similar to an audio CD.

character

A distinctive mark; an inscribed letter; one of a set of writing-symbols.

coding

Allocation of a feature code to a feature being created from constituent construction data (points and/or segments); with optional linking to an existing feature of the same [feature code](#).

continuation mark

A logical record may contain more data than can be held in a single physical record. The [physical record](#) contains a continuation mark (the penultimate character of the record in NTF) to indicate whether more data is to be found in a continuation record.

continuation record

A specific NTF term. A continuation record is used where space does not allow one logical record to be contained wholly within one [physical record](#).

coordinate pair

An X and Y value measured with reference to Cartesian axes. In mapping a coordinate pair normally consists of an easting and a northing.

copyright

Copyright is a legal property right that enables the creator of an original work to protect it from unauthorised use. Through the *Copyright, Designs and Patents Act 1988*, Crown copyright continues to subsist in all Ordnance Survey products until the end of the period of 50 years from the end of the year in which they were published, and in the case of digital data from the end of the year in which it was extracted from the Ordnance Survey database. Crown copyright is vested in The Controller of Her Majesty's Stationery Office, who has delegated powers to the Director General, Ordnance Survey for the administration of copyright in publications and data, including the determination of rules and terms under which permission for their reproduction is given.

currency

An expression of how up-to-date the data is.

data

A representation of facts, concepts or instructions in a formalised manner suitable for communication, interpretation or processing.

data capture

The encoding of data. In the context of digital mapping this includes map digitising, direct recording by electronic survey instruments and the encoding of text and attributes by whatever means.

data format

A specification that defines the order in which data is stored or a description of the way data is held in a file or record.

data point

A coordinate pair that defines the position of a point feature, or one of a series of coordinate pairs that defines a line feature.

data quality

Attributes of a dataset that define its suitability for a particular purpose, for example, completeness, positional accuracy, currency, logical structure and so on.

data structure

The defined logical arrangement of data as used by a system for data management; a representation of a data model in computer form.

data transfer medium

This is the means by which computer files are transferred from one computer to another. Transfer media may be subdivided into communications media and physical media.

data type

This defines the structure of a data item. This in turn determines the range of values it can take and the range of operations that can be applied to it. Integer, real and character string are examples of data type. Some modern programming languages allow user-defined types.

database

An organised, integrated collection of data stored so as to be capable of use by relevant applications with the data being accessed by different logical paths. Theoretically it is application-independent, but in reality it is rarely so.

dataset

An identifiable collection of related data.

derived map

A map that has been produced by reference to other source data, rather than directly from a survey.

detached part

A term applying to a part of a local government or parliamentary area that is completely surrounded by other local government or parliamentary areas, and is not connected to the parent area by direct access on the ground.

digital

Data that is expressed as numbers (digits) in computer-readable form is said to be digital.

digital archive

Archival map data stored in digital format.

digital map

A term used by Ordnance Survey to describe a particular tile of digital map data.

digital map data

The digital data required to represent a map. The data includes not only map detail but also feature header data, map header data and management data.

distinctive name

A name given to a feature or place to distinguish it from other features or places of a similar nature, for example, *River Thames*, *Park Lane Methodist Church*, *Leeds* or *New Forest*.

DXF (Data Exchange Format)

A proprietary data format, devised by Autodesk Ltd, by which digital drawings may be transferred between users of CAD systems.

eastings

See [rectangular coordinates](#).

EBCDIC (extended binary coded decimal interchange code)

An 8-bit character encoding scheme.

edgematch

The process of ensuring that data along the adjacent edges of map sheets, or some other unit of storage, matches in both positional and attribute terms.

edit

The process of validating and correcting errors in [digital map data](#). See also [update](#).

entity

Something about which data is stored in a databank or [database](#), for example, building or tree. The data may consist of relationships, attributes, positional and shape information and so on. Often synonymous with [feature](#).

extent of the realm (EOR)

The external bounding lines of OS MasterMap[®] Topography Layer data is the extent of the realm. The *Territorial Waters Jurisdiction Act 1878* and the *Territorial Waters Order in Council 1964* confirm that the extent of the realm of Great Britain as used by Ordnance Survey is properly shown to the limit of mean low water ([mean low water springs](#) in Scotland) for the time being (except where extended by parliament).

feature

An item of detail within a digital map that can be represented by a point, symbol, text or line.

feature classification record

A specific, named NTF record that lists the feature codes in use in the current [database](#).

feature code (FC)

A numeric attribute used in [digital map data](#) to describe each feature in terms either of the object surveyed or its representation on the map (or both). A feature code is equivalent to a layer in DXF.

feature identifier

A unique code to identify an individual [feature](#).

field

A specified part of a [record](#) containing a unit of data, such as the date of digitising. The unit of data may be a data element or a data item. In NTF, a field is a subdivision of a physical record. Every field has a name and a predefined interpretation.

font

The style of text character used by a printer or plotter.

footnotes

Supplementary or explanatory notes pertaining to a map sheet, which are normally included below the southern [neatline](#) of a printed map and supplied with DXF data.

foreshore

The foreshore is taken to be the area of land between [mean high water](#) (MHW), or [mean high water springs](#) (MHWS) in Scotland, and the [extent of the realm](#) (EOR).

format

The specified arrangement of data. For example, the layout of a printed document, the arrangement of the parts of a computer instruction, the arrangement of data in a [record](#).

free end

The end of a line feature that does not intersect or connect with any other line feature, that is, the point defining the free end does not share a coordinate pair with any other feature.

geographical information system (GIS)

A system for capturing, storing, checking, integrating, analysing and displaying data that is spatially referenced to the Earth. This is normally considered to involve a spatially referenced computer database and appropriate applications software.

geographic coordinates

These are coordinates, usually expressed as latitudes and longitudes, which define position on the Earth's surface.

geometric data

Data about position within an [absolute](#) or [relative coordinate](#) system.

geometric structure

The relationships, implied or explicit, between the points and lines and text forming the dataset and representing the real world.

Global Positioning System (GPS)

A system of coordinating a ground position in three-dimensions using radio transmissions from a pattern of US defence satellites.

grid

The planimetric frame of reference, for example, the [National Grid](#).

header

See [map header](#).

indicator

See [seed](#) or [seed point](#).

junction

A connection between two or more links at a common node. Junctions may be X-junctions or T-junctions.

kilobyte (Kb)

1 024 bytes; a measure of data storage capacity.

line

A series of connected coordinated points forming a simple feature with homogeneous attribution.

line feature

The spatial abstraction of an object in one dimension. Lines may intersect with other lines. They are defined as a series of two or more coordinate pairs and may be curved or straight. Curved lines consist of a series of very short straight line segments. Lines may be concurrent with other lines under certain conditions. As an object abstraction a line has no width.

line segment

A vector connecting two coordinated points.

linear feature

Map feature in the form of a line, for example, a road centreline, that may or may not represent a real-world (extant) feature.

link

Links are the representation of line features. They are made up of one or more consecutive non-intersecting link segments with common attributes between two terminating nodes. Links have no connection with other links except at the start or end, via common (shared) terminating nodes (points). All links contain their terminating coordinates. Links may form the boundaries of polygons and may be shared between polygons.

map

A graphical or digital representation of the landscape, including natural and/or man-made features.

map generalisation

The process of reducing the complexity of the detail on a map when reducing the map scale.

map header

Data at the start of the digital map file describing that data. It may contain information on the source and history of the [geometric data](#) within the map and the coordinate system in use.

map scale

The ratio between the extent of a feature on the map and its extent on the ground, normally expressed as a representative fraction, for example, 1:1250 scale or 1:50 000 scale.

mean high water/springs (MHW or MHWS)

Depiction of the encroachment of land by tidal waters at mean highest levels – spring tides in Scotland.

mean low water/springs (MLW or MLWS)

Depiction of limits of tidal waters at mean lowest ebb – spring tides in Scotland.

megabyte (Mb)

1 048 576 bytes, a measure of data storage capacity.

Mid/Mif

Mid is a MapInfo database and Mif is a MapInfo Interchange, which is an ASCII file format and is used for export. Tabular data is held in a file with a '.mid' extension and graphic data is held in a file with a '.mif' extension. Mif files can be translated into other formats and used with other programmes.

name or text feature

The proper name or label of an object (real world) or feature (object abstraction) consisting of one or more text strings. A name position is defined by a coordinate pair.

National Grid

The metric grid on a Transverse Mercator projection used by Ordnance Survey on all post-war mapping to provide an unambiguous spatial reference in Great Britain for any place or [entity](#), whatever the map scale.

neatline

The outer grid lines forming the boundary of the map sheet.

node

An object representation of a point that either does not form any part of a [link](#) (isolated node or polygon seed point); or is the representations of a point at the start or end of a link (terminating node). The position of a node is defined by a single coordinate pair, which is repeated within all links logically connected at that node and/or containing it.

northings

See [rectangular coordinates](#).

NTF (National Transfer Format)

A format designed in 1988 specifically for the transfer of spatial information. Administered by the British Standards Institution (BSI), its present version (2.0) conforms to BS 7567 (see also [DXF](#)).

orientation

Orientation of a point or a [text feature](#), measured in degrees anticlockwise from grid east.

origin

The zero point in a system of rectangular Cartesian coordinates.

physical record

In NTF, a physical record may be fixed length (in which case, it contains 80 characters) or variable length (which contains up to 80 characters).

point

A zero-dimensional spatial abstraction of an object represented as a coordinate pair.

point and line data structure

A form of vector data structure designed for map production in which all map features are designated as points, lines or text. Point and line data does not carry the topological relationships between features.

point feature

A zero-dimensional spatial abstraction of an object with its position defined by a coordinate pair. Points may also be represented by symbols, which may have attributes such as orientation and size.

polygon

Polygons are representations of areas. A polygon is defined as a closed line or perimeter that completely encloses a contiguous space and is made up of one or more links. At least one node occurs on the perimeter of a polygon where the bounding link completes the enclosure of the area. There may be many nodes connecting the bounding links of a polygon. Links may be shared between polygons. Polygons may wholly contain other polygons; or be contained within other polygons. Each may contain a single isolated node (seed point) that identifies the polygon.

polygon boundary

The [link](#) or links that enclose a [polygon](#), projected into the horizontal plane.

polygon point

See [representative point](#).

polygon seed

See [seed](#).

positional accuracy

The degree to which the coordinates define a point's true position in the world, directly related to the spheroid and/or projection on which the coordinates system is based.

precision

The exactness with which a value is expressed, whether the value be right or wrong.

record

A set of related data fields grouped for processing.

recording format

The logical and/or physical levels of the protocol governing the laying down of data on the physical [transfer medium](#).

rectangular coordinates

Also known as x-y coordinates and as [eastings](#) and [northings](#). These are two-dimensional coordinates that measure the position of any point relative to an arbitrary origin on a plane surface, for example, a map projection, a digitising table or a VDU screen.

relative accuracy

Relative accuracy compares the distance between features measured on the ground to the corresponding information contained in the map data.

When measuring between data points represented on the map it is worth noting that some distortion may occur due to the materials and process used to produce the map.

relative coordinates

A coordinate pair or triplet measured relative to another point in the coordinate system in which it lies, rather than from the origin. (See also [absolute coordinates](#).)

representative point

A point within a [polygon](#) that can be used to carry the attributes of the whole [polygon](#), for example, owner or land use type. Also called [area seed](#), peg point, point label, polygon point, polygon seed.

resolution

A measure of the ability to detect quantities. High resolution implies a high degree of discrimination but has no implication as to [accuracy](#). For example, in a collection of data in which the coordinates are rounded to the nearest metre, resolution will be 1 metre, but the accuracy may be ± 5 metres or worse.

seed

A seed is a digitised point within an area, often a defined polygon, for example, a lake or woodland; but not always, for example, a geographical seed such as the South Downs. (See also [representative point](#).)

seed point

A coordinated point within an area to which alphanumeric information may be attached.

segment

A [link](#) or [line](#) defined by two consecutive coordinates in a line string.

Shapefile or '.shp'

ESRI Shapefiles are a simple, non-topological format for storing the geometric location and attribute information of geographic features. A Shapefile is one of the spatial data formats that you can work with in ArcView GIS.

source scale

The scale of the source information from which the map was digitised, that is, the scale of survey for a basic-scale map, or the scale of the source map for a derived map.

structure

See [data structure](#).

structured data

Data within which collections of features (of any type) form objects. Topographically-structured data also contains topological information defining the relationships between features and objects.

structured node

The topological expression of any point, whether isolated or at the end of a [link](#).

symbol feature

A feature represented by a graphical sign with a specific meaning, for example, a triangulation pillar or a benchmark.

terminator

A character, or character string, or field or record used to signal the end of a record or section or volume or database.

text coordinates

Each text feature has a start-of-text coordinate that is digitised.

text feature

A free-standing text string in the digital data describing a feature, or particular instance of a feature, for example, *Factory* or *ACACIA AVENUE*.

text height

The height at which a text string is plotted and/or displayed. This information is included in the feature header of the text feature.

text position

See [text coordinates](#). Also known as original digitised position.

text string

The set of characters to be plotted as a text feature; it is indivisible in the data.

topographic database

A [database](#) in which data relating to the physical features and boundaries on the Earth's surface is held.

topography

Topography is the study of the physical features of the earth. A topographic map's principal purpose is to portray and identify the features of the earth.

transfer format

The [format](#) used to transfer data consistently between computer systems. In general usage, this can refer not only to the organisation of data but also to the associated information, such as [attribute codes](#), which are required in order to successfully complete the transfer.

transfer medium

The physical medium on which digital data is transferred from one computer system to another, for example, CD-ROM.

transfer set

A specific NTF term for the data, together with its supporting information, that the customer receives.

update

The process of adding to and revising existing digital map data to take account of change.

urban area

An area containing a concentration of buildings and other structures.

vector

A straight line joining two data points.

vector data

Positional data in the form of coordinates of the ends of [line segments](#), points, text positions and so on.

volume

A physical unit of the transfer medium, that is, a single CD-ROM, DVD and so on.